



IEEE Recommended Practice for Cement Plant Power Distribution

Industry Applications Society

Sponsored by the
Cement Industry Committee

277TM

IEEE
3 Park Avenue
New York, NY 10016-5997, USA

12 October 2007

IEEE Std 277TM-2007
(Revision of
IEEE Std 277-1994)

IEEE Std 277™-2007

(Revision of
IEEE Std 277-1994)

IEEE Recommended Practice for Cement Plant Power Distribution

Sponsor

**Cement Industry Committee
of the
IEEE Industry Applications Society**

Approved 17 May 2007

IEEE-SA Standards Board

Abstract: Electrical distribution systems in cement plants that would result in satisfactory equipment utilization, reliability, performance, safety, and low maintenance—all at a reasonable cost—are recommended.

Keywords: alternate power source, power distribution, primary distribution voltage, quarry distribution, secondary unit substation, surge arresters

The Institute of Electrical and Electronics Engineers, Inc.
3 Park Avenue, New York, NY 10016-5997, USA

Copyright © 2007 by the Institute of Electrical and Electronics Engineers, Inc.
All rights reserved. Published 12 October 2007. Printed in the United States of America.

IEEE is a registered trademark in the U.S. Patent & Trademark Office, owned by the Institute of Electrical and Electronics Engineers, Incorporated.

National Electrical Safety Code and NESC are both registered trademarks and service marks of the Institute of Electrical and Electronics Engineers, Inc.

National Electrical Code and NEC are both registered trademarks of the National Fire Protection Association, Inc.

Print: ISBN 0-7381-5625-6 SH95693
PDF: ISBN 0-7381-5626-4 SS95693

No part of this publication may be reproduced in any form, in an electronic retrieval system or otherwise, without the prior written permission of the publisher.

IEEE Standards documents are developed within the IEEE Societies and the Standards Coordinating Committees of the IEEE Standards Association (IEEE-SA) Standards Board. The IEEE develops its standards through a consensus development process, approved by the American National Standards Institute, which brings together volunteers representing varied viewpoints and interests to achieve the final product. Volunteers are not necessarily members of the Institute and serve without compensation. While the IEEE administers the process and establishes rules to promote fairness in the consensus development process, the IEEE does not independently evaluate, test, or verify the accuracy of any of the information contained in its standards.

Use of an IEEE Standard is wholly voluntary. The IEEE disclaims liability for any personal injury, property or other damage, of any nature whatsoever, whether special, indirect, consequential, or compensatory, directly or indirectly resulting from the publication, use of, or reliance upon this, or any other IEEE Standard document.

The IEEE does not warrant or represent the accuracy or content of the material contained herein, and expressly disclaims any express or implied warranty, including any implied warranty of merchantability or fitness for a specific purpose, or that the use of the material contained herein is free from patent infringement. IEEE Standards documents are supplied “**AS IS.**”

The existence of an IEEE Standard does not imply that there are no other ways to produce, test, measure, purchase, market, or provide other goods and services related to the scope of the IEEE Standard. Furthermore, the viewpoint expressed at the time a standard is approved and issued is subject to change brought about through developments in the state of the art and comments received from users of the standard. Every IEEE Standard is subjected to review at least every five years for revision or reaffirmation. When a document is more than five years old and has not been reaffirmed, it is reasonable to conclude that its contents, although still of some value, do not wholly reflect the present state of the art. Users are cautioned to check to determine that they have the latest edition of any IEEE Standard.

In publishing and making this document available, the IEEE is not suggesting or rendering professional or other services for, or on behalf of, any person or entity. Nor is the IEEE undertaking to perform any duty owed by any other person or entity to another. Any person utilizing this, and any other IEEE Standards document, should rely upon the advice of a competent professional in determining the exercise of reasonable care in any given circumstances.

Interpretations: Occasionally questions may arise regarding the meaning of portions of standards as they relate to specific applications. When the need for interpretations is brought to the attention of IEEE, the Institute will initiate action to prepare appropriate responses. Since IEEE Standards represent a consensus of concerned interests, it is important to ensure that any interpretation has also received the concurrence of a balance of interests. For this reason, IEEE and the members of its societies and Standards Coordinating Committees are not able to provide an instant response to interpretation requests except in those cases where the matter has previously received formal consideration. At lectures, symposia, seminars, or educational courses, an individual presenting information on IEEE standards shall make it clear that his or her views should be considered the personal views of that individual rather than the formal position, explanation, or interpretation of the IEEE.

Comments for revision of IEEE Standards are welcome from any interested party, regardless of membership affiliation with IEEE. Suggestions for changes in documents should be in the form of a proposed change of text, together with appropriate supporting comments. Comments on standards and requests for interpretations should be addressed to:

Secretary, IEEE-SA Standards Board
445 Hoes Lane
Piscataway, NJ 08854
USA

Authorization to photocopy portions of any individual standard for internal or personal use is granted by the Institute of Electrical and Electronics Engineers, Inc., provided that the appropriate fee is paid to Copyright Clearance Center. To arrange for payment of licensing fee, please contact Copyright Clearance Center, Customer Service, 222 Rosewood Drive, Danvers, MA 01923 USA; +1 978 750 8400. Permission to photocopy portions of any individual standard for educational classroom use can also be obtained through the Copyright Clearance Center.

Introduction

This introduction is not part of IEEE Std 277-2007, IEEE Recommended Practice for Cement Plant Power Distribution.

This recommended practice has been revised to reflect needed technical changes that have been suggested since the document was last published in 1994.

IEEE Std 277-2007 reflects the thinking of members of the Power Generation and Distribution Working Group, consisting of members from cement plants, machinery manufacturers, electrical equipment manufacturers, and cement plant designers and builders.

Notice to users

Errata

Errata, if any, for this and all other standards can be accessed at the following URL: <http://standards.ieee.org/reading/ieee/updates/errata/index.html>. Users are encouraged to check this URL for errata periodically.

Interpretations

Current interpretations can be accessed at the following URL: <http://standards.ieee.org/reading/ieee/interp/index.html>.

Patents

Attention is called to the possibility that implementation of this recommended practice may require use of subject matter covered by patent rights. By publication of this recommended practice, no position is taken with respect to the existence or validity of any patent rights in connection therewith. The IEEE shall not be responsible for identifying patents or patent applications for which a license may be required to implement an IEEE standard or for conducting inquiries into the legal validity or scope of those patents that are brought to its attention.

Participants

At the time this recommended practice was submitted to the IEEE-SA Standards Board for approval, the Power Generation and Distribution Working Group had the following membership:

Jean-Paul Morel, *Chair*

Rick L. Labahn, *Vice Chair*

Randall Clary
George J. Fergades

Mark A. Huber
Michael D. Seal

Michael Sebasto
John Stroker

The following members of the individual balloting committee voted on this recommended practice. Balloters may have voted for approval, disapproval, or abstention.

Ali al Awazi
Wallace B. Binder, Jr.
Donald M. Colabardino
Tommy P. Cooper
Stephen J. Coppinger
George J. Fergades
Randall C. Groves
Werner Hoelzl
David A. Horvath
Dennis Horwitz

John A. Houdek
Mark A. Huber
Rick L. Labahn
Keith N. Malmedal
Gary L. Michel
Jean-Paul Morel
Jerry R. Murphy
Michael S. Newman
Douglas S. Phares
Louie J. Powell, Jr.

Clayton H. Reid
Charles W. Rogers
Bartien Sayogo
James L. Schaadt, Jr.
Michael D. Seal
D. K. Shah
Gil Shultz
Roderick H. Simmons
John A. Vergis
Ahmed F. Zobaa

When the IEEE-SA Standards Board approved this recommended practice on 17 May 2007, it had the following membership:

Steve M. Mills, *Chair*
Robert M. Grow, *Vice Chair*
Donald F. Wright, *Past Chair*
Judith Gorman, *Secretary*

Richard DeBlasio
Alexander D. Gelman
William R. Goldbach
Arnold M. Greenspan
Joanna N. Guenin
Julian Forster*
Kenneth S. Hanus
William B. Hopf

Richard H. Hulett
Hermann Koch
Joseph L. Koepfinger*
John D. Kulick
David J. Law
Glenn Parsons
Ronald C. Petersen
Tom A. Prevost

Narayanan Ramachandran
Greg Ratta
Robby Robson
Anne-Marie Sahazizian
Virginia C. Sulzberger
Malcolm V. Thaden
Richard L. Townsend
Howard L. Wolfman

*Member Emeritus

Also included are the following nonvoting IEEE-SA Standards Board liaisons:

Satish K. Aggarwal, *NRC Representative*
Alan H. Cookson, *NIST Representative*

Jennie Steinhagen
IEEE Standards Program Manager, Document Development

Patricia A. Gerdon
IEEE Standards Program Manager, Technical Program Development

Contents

1. Overview	1
1.1 Scope	1
1.2 Purpose	1
2. Normative references.....	1
3. Power distribution for a new plant	2
3.1 Main plant distribution substation	2
3.2 Cable.....	11
3.3 Secondary unit substations	13
3.4 Safety ground check monitoring.....	17
4. Power distribution for a plant expansion	17
4.1 Changing 2400 V system to 4160 V if total expanded plant capacity exceeds 10000 kVA (self-cooled).....	18
4.2 Deriving utility power for existing 2400 V equipment from the high-voltage incoming line utility service or from the proposed new 4160 V system	18
4.3 Grounding the existing 2400 V system through neutral-grounding resistors	18
4.4 Abandoning existing generation and purchase total power from the utility	18
4.5 Using interlocked armored cable carried on trays	19
5. Quarry distribution utilizing high-resistance grounded systems for portable electrical equipment.....	19
5.1 Quarry distribution transformer	19
5.2 Primary distribution	21
5.3 Distribution 600 V and below.....	25
6. Harmonics	25
7. Figures.....	27

IEEE Recommended Practice for Cement Plant Power Distribution

1. Overview

1.1 Scope

This document has been developed as a recommended practice for electrical distribution systems in cement plants with the objective of satisfactory equipment utilization, reliability, performance, safety, and low maintenance—all at a reasonable cost.

1.2 Purpose

The purpose of this recommended practice is to provide guidance in established practices for the design, application, installation, and protection of electrical distribution systems in cement plants. This recommended practice will be used to augment some of the principles outlined as they apply to cement plants.

2. Normative references

The following referenced documents are indispensable for the application of this recommended practice (i.e., they must be understood and used, so each referenced document is cited in text and its relationship to this document is explained). For dated references, only the edition cited applies. For undated references, the latest edition of the referenced document (including any amendments or corrigenda) applies.

Accredited Standards Committee C2-2007, National Electrical Safety Code® (NESC®).¹

IEEE Std 141™-1993, IEEE Recommended Practice for Electric Power Distribution for Industrial Plants (*IEEE Red Book*™).^{2, 3}

¹The NESC is available from the Institute of Electrical and Electronics Engineers, 445 Hoes Lane, Piscataway, NJ 08855-1331, USA (<http://standards.ieee.org/>).

²The IEEE standards listed in this clause are available from the Institute of Electrical and Electronics Engineers, 445 Hoes Lane, Piscataway, NJ 08855-1331, USA (<http://standards.ieee.org/>).

³IEEE publications are available from the Institute of Electrical and Electronics Engineers, 445 Hoes Lane, Piscataway, NJ 08855-1331, USA (<http://standards.ieee.org/>).

IEEE Std 142™-1991, IEEE Recommended Practice for Grounding of Industrial and Commercial Power Systems (*IEEE Green Book™*).

IEEE Std 242™-1986, IEEE Recommended Practice for Protection and Coordination of Industrial and Commercial Power Systems (*IEEE Buff Book™*).

IEEE Std 446™-1995, IEEE Recommended Practice for Emergency and Standby Power Systems for Industrial and Commercial Applications (*IEEE Orange Book™*).

IEEE Std 450™-2002, IEEE Recommended Practice for Maintenance, Testing, and Replacement of Vented Lead-277-1994 Acid Batteries for Stationary Applications.

IEEE Std 519™-1992, IEEE Recommended Practices and Requirements for Harmonic Control in Electrical Power Systems.

IEEE Std 625™-2001, IEEE Recommended Practices to Improve Electrical Maintenance and Safety in the Cement Industry Power Distribution for a New Plant.

IEEE Std C37.2™-1996, IEEE Standard Electrical Power System Device Function Numbers and Contact Designations.

NFPA 70, National Electrical Code® (NEC®).⁴

U.S. Department of Labor, Mine Safety and Health Administration (MSHA), CFR 30 Part 56—Safety and Health Standards Surface Metal and Nonmetal Mines.⁵

U.S. Department of Labor, Mine Safety and Health Administration (MSHA), CFR 30 Part 57—Safety and Health Standards Underground Metal and Nonmetal Mines. Subpart K—Electricity.

3. Power distribution for a new plant

Factors to consider in new plant construction include the main plant distribution substation, what cables to use, secondary unit substations, and safety ground check monitoring devices.

3.1 Main plant distribution substation

Source of plant power and the ownership of the main substation can greatly affect both the capital and operating costs of a plant. Type of equipment and substation design will be dependent upon these decisions, as well as selected voltage levels and plant load.

3.1.1 Purchased power vs. on-site generation or co-generation

A study should be performed to determine the economics of purchased power (utility) vs. on-site generation or co-generation. The trend in cement plants is to purchase power from the utility instead of generating power. The decision to purchase or generate power depends primarily upon economics. Many operators believe that the possible increased production by the use of efficient kilns more than offsets the

⁴The NEC is published by the National Fire Protection Association, Batterymarch Park, Quincy, MA 02269, USA (<http://www.nfpa.org/>). Copies are also available from the Institute of Electrical and Electronics Engineers, 445 Hoes Lane, Piscataway, NJ 08855-1331, USA (<http://standards.ieee.org/>).

⁵U.S. Department of Labor Mine Safety and Health Administration (MSHA) publications are available from the U.S. Department of Labor Mine Safety and Health Administration at <http://msha.gov>.

additional cost of purchased power in most locations in the United States. Other advantages in using utility power are:

- Possibly better voltage regulation during the starting of large motors
- Greater reliability of a larger system
- Absence of operating problems associated with power generation

Explore the possibility of a form of co-generation to be operated with a new plant. Available co-generation options include:

- a) Produce electricity for a portion of the plant (no large motors). This portion of the plant would not normally be connected to the utility.
- b) Sell all the electricity the plant produces to the utility and purchase all the electricity the plant uses from the utility. One possible drawback to this would be the cost of transforming the electricity produced to the distribution voltage of the utility.
- c) Produce electricity and tie in with the plant's distribution. This may complicate coordination and protection.
- d) Pursue deregulation opportunities as allowed.

3.1.2 Locating plant substations above 15 kV

Locate the high-voltage (above 15 kV) part of the main substation outdoors on the windward side of the plant. The costly practice of locating plant substations (above 15 kV) indoors or under a roof to minimize dust settlement is no longer considered necessary.

3.1.3 Ownership of outdoor part of main plant substation

Make a study to determine whether the outdoor part of the main plant substation is to be owned by the plant or by the utility. Here again, economics, including initial, operational, and maintenance costs, should be compared with local utility rates at different voltages to determine who should own the outdoor substation. Excluding economics, the plant purchasing the substation has the advantage of choosing the substation equipment arrangement that best fits its needs. However, utility ownership may enable a quicker restoration of power subsequent to equipment failure since utilities generally stock spare equipment.

Wherever the substation is located, make sure the plant has access to the main metering equipment (computer capture of utility pulses) so that the plant knows instantaneous kilowatt usage. Time of use and level of use are important economic considerations.

A study is indicated instead of a recommendation because of the wide variation of utility rates and policies.

3.1.4 Extra-creepage insulators and bushings

Use extra-creepage insulators and bushings on the exposed electric equipment in the outdoor substation. The use of extra-creepage porcelain in the outdoor substation extends the time between cleaning periods and helps keep flashovers to a minimum. Many operators use silicone waxes or greases to facilitate the periodic cleaning of exposed insulators and bushings.

Bushings at the medium voltage level (2.4 kV to 13.8 kV) are best kept enclosed in terminal chambers. It is also desirable to keep the number of bushings to a minimum by the use of three-phase instead of single-phase transformers.

3.1.5 Alternate power source

Provide for an alternate power source to the plant, especially for critical loads. This power source could be a full-capacity transmission line to the plant, a small-capacity line at some lower voltage, standby generation, or some combination of these. The use of a loop or alternate transmission line allows total plant operation, after a short delay, in the event of a transmission line failure. A low-capacity alternate feed or standby generation allows operation of critical loads during the line failure outages. Standby generation should be exercised under load once a week to help ensure its availability when needed. If possible, standby generators should also be exercised once a year under full load conditions by means of an external resistive load bank [see IEEE Std 446-1995 (*IEEE Orange Book*)]⁶.

Some utilities offer rebates for remote interruption of plant power. If this is the case, and if economically viable, then provisions should be made for this interruption in the system design. This could include putting the shipping department and plant offices on a separate meter. Also, some utilities offer rebates for shedding a portion of the plant load on notification. In this case, no separate meter is needed.

3.1.6 Use of circuit breakers

Use circuit breaker or circuit breakers for primary protection of substation apparatus. Circuit breakers are preferred over fuses for substation primary protection as they allow the use of fast, sensitive relays that quickly act to isolate faulted equipment and more easily coordinate with other protective devices used. When using a circuit breaker on the primary of a substation transformer, it is possible to extend the zone of protection to include the transformer secondary winding and the secondary main breaker. This would be done by including a ground current transformer with ground relay (50G, 51G, or 50/51G) and/or transformer differential relaying for transformer protection. This additional relaying would supplement the primary over-current relaying to protect against ground faults and high impedance phase-to-phase faults occurring in the transformer secondary winding or between the transformer secondary winding and the main secondary breaker. Fuses' or circuit breakers' primary overcurrent relaying (50/51G) would be insensitive to faults occurring in this zone and would not clear the fault until considerable damage had been done to the transformer.

Ground faults occurring in the substation transformer secondary or between the transformer secondary and the main secondary circuit breaker cannot be isolated by the main secondary circuit breaker located on the load side of the ground fault.

CAUTION

These ground faults, when limited by a neutral-grounding resistor, are not seen by transformer primary fuses and must be isolated by a primary circuit breaker. If not isolated, these ground faults create a safety hazard and may result in the destruction of the faulted substation equipment and the grounding resistor.

A primary circuit breaker also enables the use of differential relays that quickly initiate action to clear faults, keeping fault damage to a minimum. The unfaulted half of a double-ended substation can usually be quickly restored to service subsequent to an outage initiated by a properly relayed substation using a primary circuit breaker. Where cost prohibits the use of a local primary circuit breaker, a means of remote tripping through a pilot scheme, carrier scheme, or a grounding relay can be used to affect remote tripping of a circuit breaker to isolate substation faults. When the transformer primary protection are switch and fuses, a grounding switch may be employed to place an intentional ground fault on the system to cause the upstream breaker to open, thus isolating the fault.

⁶Information on references can be found in Clause 2.

3.1.7 Double-ended substation

Use a double-ended substation in sizes above the 5000 kVA to 7500 kVA capacity range. The double-ended substation, as used here, is defined as a substation having more than one three-phase step-down transformer. More than one low-side bus may be used where required (see Figure 1 and Figure 2 in Clause 7).

The double-ended substation allows for greater reliability and flexibility. Double-ended substations permit insulator cleaning, no-load tap changing, and reduced-capacity operation without a power outage. The double-ended arrangement is desirable at lower capacities, but the additional cost of the double-ended arrangement usually does not justify its use in sizes below 5000 kVA. (Substation costs may be estimated from Figure 1 and Figure 2 for the single-ended and double-ended substations.)

3.1.8 Surge arresters

Use station or intermediate-type surge arresters selected to coordinate with equipment insulation levels to protect exposed substation equipment and rotating machines against lightning surges. Surge protection is most effective when applied at the terminals of the apparatus to be protected. Equipment connected by cable to an exposed (outdoor lines subject to lightning strokes) power source or directly to an exposed source generally requires lightning protection. Effective arrester protection requires that the arresters be installed with a low-surge impedance discharge path to ground. Where feasible, connect the arrester ground lead to the ground lead of the protected equipment. Leads should be kept as short as possible.

Protection against lightning is usually provided at the outdoor substation by station or intermediate-type surge arresters and overhead ground wires. Apparatus energized from exposed circuits should have arrester protection at the terminals of the apparatus to be protected. Apparatus energized through cables from exposed circuits should usually have arrester protection at the junction of the cable and the exposed source. If cables connect to the outdoor transformer terminal chamber, and the transformer primary source is exposed, the transformer should have primary arrester protection.

Rotating machines have lower basic impulse insulation levels (BIL) than liquid-filled transformers, switchgear, etc. Thus, all rotating machines connected to exposed circuits should be protected by lightning arresters and surge capacitors at or very near to [less than 1 m (3 ft) from] the machine terminals. The lightning arrester limits the surge level while the capacitor reduces the slope to prevent any possible motor winding damage. Both are required for proper protection. Even though large important rotating machines are not connected directly to exposed lines, it is still desirable to use surge arresters and surge capacitors to reduce the effects of induced lightning and switching surges. Extra creepage bushings capable of operating in the contaminants around the cement plant should be used.

Surge arresters for resistance-grounded systems usually used in cement plants are rated for line-to-line voltage [see IEEE Std 142-1991 (*IEEE Green Book*)].

3.1.9 Grounding the power system

Grounding the power system through a neutral-grounding resistor or resistors at the primary medium voltage level (2.4 kV to 13.8 kV) is recommended. Power systems are grounded to minimize the magnitude of the transient overvoltages that occur in ungrounded systems during ground faults. To minimize the damage due to the ground-fault current that flows in a solidly grounded system during a ground fault, a neutral-grounding resistor should be used. Limiting the ground-fault current will minimize the damage to the large motors used in the plant at the distribution-voltage level.

A 10 s resistor rating is satisfactory for plant distribution service, when ground faults are relayed to trip the faulted circuit.

To minimize the transient overvoltages during arcing grounds, the neutral ground resistor must limit the fault current allowed to flow during faults to a value that is slightly greater than the system capacitive charging current. When the system is designed to alarm on the detection of a ground fault and operate until such time as it is convenient to clear the fault, then high-resistance grounding should be employed. For high-resistance grounding, the neutral-grounding resistor should be sized to allow capacitive charging current to flow during ground faults. Since the charging current increases with system voltage, the application at 480 V is very favorable, less so at 4160 V, and at 13 800 V has not been successful due to the very large charging current. In high-resistance grounded systems the typical ground currents are 5 A to 15 A. In low-resistance grounded systems, typical values range from 50 A to 600 A. When a ground fault is detectable, the protective device closest to the fault is tripped.

In low-resistance grounded systems, the value of resistance used should be low enough to allow the flow of sufficient ground-fault current to be selectively relayed with an adequate margin. Ground-fault current should not be limited to less than the system charging current (usually less than 15 A). Generally, the combination of grounding resistor and ground relaying used should result in the protection of 90% of the windings of motors and transformers. Effective protection of equipment is realized if ground relays pick up at 10% or less of the maximum ground-fault current.

3.1.10 Using one or more feeder circuit breakers

Use one or more feeder circuit breakers for each operating department at the medium-voltage level. This sectionalizing of loads allows independent departmental (or production unit) operation and facilitates the metering of each department. The trend is toward the universal use of metal-clad switchgear with removable-type circuit breakers. A tie breaker is desirable in the double-ended metal-clad lineup for increased flexibility. It is desirable to use an additional circuit breaker to separate large mill motors from auxiliary systems. This facilitates relay coordination and allows closer protection of the connected equipment.

Either indoor or outdoor metal-clad circuit breakers may be used, depending upon available plant area. Indoor metal-clad circuit breakers in clean pressurized rooms are preferred over outdoor circuit breakers. The tripping voltage should be at least 125 V to minimize relay contact continuity failures due to dust [see IEEE Std 142-1991 (*IEEE Green Book*)].

3.1.11 Allowing for margin in substation capacity

Approximately one-third extra apparent power capacity (in kilovoltamperes) over that needed for present plant operation is desirable in the initial substation installation. Circuit breakers also should allow for anticipated increase in utility short-circuit capacity for a period of approximately 10 years. Consideration should be given to the providing of features in the substation to facilitate subsequent expansion.

It is desirable to choose the transformer's size of double-ended substations to be large enough to enable starting the large mill motors on a single transformer within tolerable voltage regulation (see 3.1.13). Mill torque limits should be observed both on single- and two-transformer operations.

A typical suggested substation size is 5000 kVA (with fans for 6250 kVA capacity) for each 200 000 ton of annual production capacity. The use or provision for future use of fans on the substation transformers should be considered.

3.1.12 Primary distribution voltage for plants

Use 4160 V as the primary distribution voltage for plants of 20 000 kVA and below. Above 20 mVA, either use the split-bus 4160 V system or the 13.8 kV system. Above 35 MVA, use the split-bus 13.8 kV system. The interrupting and momentary current capacity of the 4160 V circuit breakers and motor controls limits

the allowable short-circuit capacity and, thus, the substation apparent power on a bus. However, most existing plants have short-circuit capacities within the limits of 4160 V equipment.

When short-circuit capacities are above the limits of 4160 V equipment, the 4160 V bus can be split to keep short-circuit capacities within equipment ratings. A higher distribution voltage can be used as well with the available equipment having higher short-circuit capacities. The next economical voltage choice is usually 13.8 kV.

The use of 13.8 kV as a primary distribution voltage may require an additional transformation to 4160 V or 2400 V to enable the economical use of large motors at the lower primary distribution voltages. However, the double transformation increases system impedance and voltage drop during the starting of the large grinding-mill motor and should be taken into account. This problem can be eliminated or greatly reduced if all motors of 2500 HP and greater are served at the 13.8 kV level. It is recommended that a study be made to determine the economic motor voltage for plants of 20 mVA and above.

Figure 6 shows relative costs for the electric apparatus at several distribution-voltage levels [see National Electrical Safety Code® (NESC®) (Accredited Standards Committee C2-2007) and IEEE Std 141-1993 (*IEEE Red Book*)].

3.1.13 Limiting voltage drop

Design the power system to limit voltage drop during starting large motors (at the distribution voltage) to a maximum of 10% of system nominal voltage at the motor terminals. The possibility of equipment malfunction increases when the voltage drop exceeds 10%. Special precautions to maintain control voltage may be required where a greater than 10% drop in system voltage is anticipated.

During normal running, voltage at the large motors at the distribution voltage should not vary more than 5% of rated motor voltage.

A motor starting study, short-circuit study, and a coordination study are required to properly design the power system.

When purchasing new transformers, it may be economical to incorporate automatic tap changers on the new transformers to enable voltage level changes.

3.1.14 Isolating synchronous machines

Isolate synchronous machines from the utility system prior to any reclosing action subsequent to a plant power interruption due to the utility system. A power interruption allows the synchronous machines to shift in phase position in respect to the utility system. Subsequent application of power to the machines, when out of synchronism, may result in inrushes and torque well above drive equipment mechanical limits. High-speed underfrequency relays without any intentional time delay can usually act to isolate loaded synchronous motors prior to a reclosing action. Note that lightly loaded motors or motors connected to high inertia loads or both may not decelerate in time to allow underfrequency relay action prior to utility reclosing.

Coordination with the utility to block or delay reclosing is suggested.

3.1.15 Choosing and setting protective relays

Choose and set protective relays to selectively initiate the isolation of faults on the primary distribution system. Periodically, check relays to ensure proper operation. A short-circuit and relay coordination study should be made to enable selective isolation of both phase and ground overcurrents for the load on each feeder back to the utility system.

Suggested relaying is outlined in 3.1.15.1, 3.1.15.2, 3.1.15.3, and 3.1.15.4 [see also Figure 7 in Clause 7 and IEEE Std 242-1986 (*IEEE Buff Book*)].

NOTE—Specific relay choices cannot be made since relay curves vary with different manufacturers. Care must be exercised to ensure that the proper curve is specified.⁷

3.1.15.1 Department feeder circuit breakers at the primary distribution voltage level

- a) *Phase*. Inverse time, moderately inverse time, very inverse time, or extremely inverse time relays, or equivalent, as required to properly coordinate with the connected load protective devices. The extremely or very inverse time relay may be required to coordinate with fuses in motor starters over 600 V and when used on the primaries of the substation secondary unit transformers. If the feeder circuit breaker feeds directly to an unfused secondary unit substation transformer, the phase relays should also have instantaneous trip attachments set above the maximum asymmetrical fault expected at the connected low-voltage substation secondary.

The options of the different relays of inverse time, moderately inverse time, very inverse time, or extremely inverse time for both phase and ground should be compared to the solid state microprocessor-based systems. The advantages of the new solid state units are many, including communications with a computer monitoring system, closer coordination, lower cost, and built-in metering.

Refer to 3.3.6 for recommended use of low-voltage secondary unit substation fuses.

Set phase relays to pick up at as low a value of current and to operate at as fast a time as feasible with the connected equipment. The relays should initiate clearing of fault on equipment directly connected to the feeder breaker within the capacity of the connected cable and equipment [see Figure 8 in Clause 7 and National Electrical Code® (NEC®) (NFPA 70)].

Feeder circuit breakers acting as control for large motors should have relays provided expressly for motor protection. Relays recommended are thermal (or temperature), damper-winding protection, undervoltage, reverse phase, ground fault, and differential protection. Large important motor controls may include current-balance relays, negative-sequence relays, and temperature indicators. A complete packaged programmable microprocessor motor protector providing ANSI Device Function Numbers 38, 46, 49, 50 50N, 51, 86, and 87 (see IEEE Std C37.2-1996) is replacing the individual protective relays. Synchronous motor controls should include additional field loss, synchronizing, pull out, instantaneous undervoltage, and incomplete-sequence relays.

- b) *Ground*. Inverse, moderately inverse, very inverse, or extremely inverse time relays, or equivalent, as required to coordinate with ground relays included in motor starters over 600 V on the resistance-grounded system, should be equipped with a ground relay to quickly initiate the isolation of motor ground faults without affecting the rest of the primary distribution system. However, the motor starter must have sufficient interrupting capacity to isolate the maximum ground-fault current as limited by the neutral-grounding resistors. If ground relays are not included in the motor starters, the feeder breaker ground relays should act to quickly isolate ground faults.

⁷Notes in text, tables, and figures of a standard are given for information only and do not contain requirements needed to implement this standard.

Instantaneous tripping methods are desirable on ground faults for feeder breakers serving secondary unit substation transformers, whether fused or unfused. With the resistance-grounded system, it is unlikely that secondary unit substation transformer primary fuses will see or isolate transformer ground faults within the desired time. Instantaneous relays are sometimes used as ground-fault protection when used with balance flux (window-type) current transformers. However, when the residual connection of phase-current transformers is used for ground-fault relays, a time-delay relay may be required to prevent nuisance tripping due to false residual currents. In order to provide protection over 90% of the transformer primary winding, the relay should be able to detect 10% of maximum ground-fault current.

On circuits feeding 2400 V and 4160 V starters, the feeder-circuit ground relay should allow at least 0.4 s greater delay (at maximum ground-fault current) than the starter ground relay. This time can be reduced if the relays are calibrated or are of the solid state type. The starter ground relay should be instantaneous when energized from a three-phase balance flux current transformer. If the starter-phase current transformers are connected in a residual circuit to realize ground-fault protection, an inverse or very inverse time-ground relay should be used. These relays allow a time delay to minimize nuisance tripping due to false residual currents. To protect at least 90% of the motor windings, the ground relay should be set to pick up on 10% or less of the maximum ground-fault current [see IEEE Std 242-1986 (*IEEE Buff Book*)].

3.1.15.2 Secondary circuit breakers of the main plant distribution substation transformers

The options of the different relays of inverse time, moderately inverse time, very inverse time, or extremely inverse time for both phase and ground should be compared to the solid state microprocessor-based systems. The advantages of the solid state units are many, including communications with a computer monitoring system, closer coordination, lower cost, and built-in metering.

- a) *Phase*. Inverse, moderately inverse, or very inverse time relays, or equivalent, without instantaneous trip attachments, to isolate the distribution substation transformer on severe overloads and bus faults and to back up the feeder breakers. The choice of relays should be such as to coordinate with the feeder breaker relays on feeder faults.

Set relays to coordinate with the feeder-breaker relays. Adjust time to allow 0.4 s minimum greater trip time at maximum fault than the slowest feeder-breaker relay setting for coordination.

- b) *Ground*. Inverse, very inverse, moderately inverse, or extremely inverse time relays, or equivalent, without instantaneous trip attachments, to initiate isolation of bus faults and to provide backup protection on feeder ground faults. These relays should coordinate with the feeder-breaker ground-fault relays.

These ground relays can be energized from a residual connection of the phase current transformers, balance flux current transformers, or current transformers included between the neutrals of the distribution substation transformers and the neutral ground resistors.

Set ground relays to pick up at 10% or less of maximum ground-fault current from each grounding resistor (assuming a neutral-grounding resistor in each transformer neutral circuit, as shown in figure in clause). Set time to allow a minimum of 0.4 s longer time than the slowest feeder-breaker ground relay for coordination with the feeder breaker seeing maximum ground-fault current from all grounding resistors.

- c) *Differential relays.* Use transformer differential relays to quickly initiate the operation of the main transformer secondary breaker as well as the main transformer primary breaker. These relays could be energized from current transformers included in the primary bushings of the distribution substation power transformers and the current transformers in the main secondary breaker. For the double-ended unit substation (two transformers and two main secondary breakers, as shown in figure), a fault in the cable between one of the power transformers and its respective secondary breaker results in tripping both the primary and secondary breakers of the faulted transformer circuit. Quick restoration of plant power by way of the unfaulted transformer circuit is affected subsequent to isolation of the fault. Isolation of the faulted circuit is affected by opening the transformer primary switch after drawing out the transformer secondary circuit breaker [see IEEE Std 242-1986 (*IEEE Buff Book*)].

3.1.15.3 Bus tie breaker at the primary distribution voltage level

The tie breaker should be relayed to isolate bus faults and to back up feeder breakers. In the event of a fault on one side of the switchgear, it is desirable to trip the bus-tie breaker and the main transformer secondary breaker on the faulted side of the bus. This action affects the isolation of the fault without interrupting power flow to the unfaulted half of the bus. The overcurrent relays on the main transformer secondary breakers can be used to affect this simultaneous tripping and still provide backup protection on feeder faults by use of a summation circuit of current transformers on the tie breaker with those on the main breakers [see IEEE Std 242-1986 (*IEEE Buff Book*)].

3.1.15.4 Main plant distribution substation transformer primary breaker

The options of the different relays of inverse time, moderately inverse time, very inverse time, or extremely inverse time for both phase and ground should be compared to the solid state microprocessor-based systems. The advantages of the solid-state units are many, including communications with a computer monitoring system, closer coordination, lower cost, and built-in metering.

- a) *Phase.* Inverse, moderately inverse, or very inverse time relays, or equivalent, with instantaneous trip attachments chosen to coordinate with the secondary breaker of the distribution substation transformer. This breaker serves to isolate substation high-voltage faults and acts as backup protection on severe faults at the primary distribution voltage level.

Relays should be set to protect substation equipment. The relay pickup value must not exceed the values in the NEC.

- b) *Ground.* Two ground relays. One very inverse time or extremely inverse time relay, or equivalent, to initiate quick isolation of ground faults on the high-voltage side of the distribution substation. This relay is connected residually with the bushing current transformers in the primary circuit breaker. Pickup of this relay should be 10% or less of the maximum ground-fault current expected on the primary system.

The other ground relay is usually an inverse time or definite time relay, or equivalent, without instantaneous trip attachment, and connects to a current transformer (or current transformers for the double-ended unit substation) in the neutral resistor circuit(s). Or, this ground relay is a potential relay connected to an unfused potential transformer with its primary winding connected across the neutral resistor, sensing voltage as a function of ground current. A potential relay will trip on ground faults even if the grounding resistor should become open circuited.

This relay is set to coordinate with the transformer secondary breaker on secondary ground faults and serves to initiate isolation of ground faults, which may occur in the transformer secondary or between the transformer and the secondary main current breaker. This relay serves to protect thermally the intermittently rated grounding resistor, and also serves as a partial backup for the transformer differential relays. Pickup setting of this relay is at 10% or less of the

maximum ground-fault current as limited by each neutral-grounding resistor, and set to allow a minimum of 0.4 s longer time than the transformer secondary-breaker ground relay. This time can be reduced if the relays are calibrated or are of the solid state type.

Also, this relay should trip within the thermal limit of the ground resistor [see IEEE Std 242-1986 (*IEEE Buff Book*)].

3.1.16 Metering power requirements

Meter total plant power requirement and meter the power requirements of each operating department. Each feeder should have a kilowatt-hour meter, an ammeter, and possibly an indication available for feeder power factor. Demand meters, indicating 15 min or 30 min maximum demand, are sometimes used. Meter multipliers should be primary readings (multiplier multiples of 10).

Totalizer metering should include both integrating and recording meters to approximate the utility metering and to enable control of demand. A more accurate check on the utility metering requires the use of equivalent accuracy meters and equivalent accuracy and burden on current transformers.

Voltmeters are desirable on each main breaker to indicate potential of each incoming line.

Periodic tests should be made on meters to ensure accuracy.

3.1.17 Switchgear battery sets

Switchgear battery sets are required for the actual tripping potential when a protective relay functions. Various station class batteries are available with the lead-antimony being the most common (14-year life) or lead-calcium for extra life (25-year life). Care should be used with maintenance-free types as their life is shortened in ambient temperatures of 27 °C (80 °F) and up. It is most important that these substation batteries be maintained, and that alarming be installed and run to a central control room (see IEEE Std 450-2002).

3.2 Cable

Many factors must be considered when selecting the proper cables for a given application. Some of these include voltage class, current capacity, shielding, fire rating, and the operating environment.

3.2.1 Choosing cable rated for the voltage on which it is to be used

At 600 V and below, no distinction is made between grounded and ungrounded systems. However, at voltages above 600 V consideration must be given to system grounding in the choice of cable insulation thickness. Cables for the higher voltage levels are furnished with the designation of 100% insulation level for grounded or 133% insulation level for ungrounded service. When sizing cables for SCR drives using fast operation solid state switching devices, make allowances for harmonics in determining voltage and current levels and the distance between control and motor.

3.2.2 Using shielded cable for distribution voltages above 2000 V

Cable shielding, properly grounded, promotes safety in that the shield surrounds each conductor (at ground potential). Phase-to-phase faults are discouraged. Thus, with the resistance-grounded system, cable fault damage is minimized. Also, longer cable life may be realized in shielded cables as the potential gradient through the conductor insulation is being held more uniformly. Cables not protected by armor or conduit should be shielded for personnel safety.

Where interlocked armored cable is used in the cement plant, the cable should include ground wires to provide a ground return path during fault conditions.

3.2.3 Cable sizes

Use cable sizes larger than the size that may be thermally damaged by maximum fault current on the distribution system for the time required to isolate the fault. Short-time ratings of copper cables are shown in Figure 8. Consider the time to isolate the fault as the sum of the time it takes the protective breaker relay to operate plus the operating time of the circuit breaker. The commonly used circuit breakers isolate faults within 5 cycles at 60 Hz above 2 kV. Low-voltage breakers are faster and may only require 1.5 cycles to 2 cycles to clear a fault.

3.2.4 Choosing suitable cables

Choose cables suitable for the current to be carried after ensuring that the cable size is adequate for the thermal stresses caused by short-circuit currents. Cables can usually be selected on the basis of thermal capacity and continuous rating for adequate capacity as cable voltage regulation is usually not significant for the short runs in the plant area. However, the desire for selectivity may indicate a choice of larger cable than that dictated by either thermal or short-circuit current considerations alone or by both. In all cases, as a minimum, conductor selection should comply with the NEC.

Sometimes additional cables are used in feeder circuits to enable quick restoration of power by way of the unfaulted cable in the event of a fault in one of the feeder cables. Consider ambient temperatures when choosing cable capacity.

3.2.5 Using multiple cables

Consider using multiple cables where cable sizes above 500 000 cmil (250 mm) are required to realize the current capacity. Cable sizes above 500 000 cmil are difficult to handle, and an appreciable reduction in current capacity per circular mil of copper penalizes the larger sizes.

3.2.6 Installing cables

Install cables so that they are protected from moving equipment, falling objects, etc. Cables should not be routed over clinker coolers, nearby kilns, or preheater tower vessels. Cables in underground ducts or conduit are commonly used in the cement plant and are preferred by many plant engineers. The use of interlocked armored cable in rigid cable supports obviates the use of ducts or conduit. Another technique for handling power cables is the use of self-supporting aerial cables, either prefabricated or spun on the job site.

3.2.7 Installing and splicing cable

Use care in the installation and splicing of cable. In general, all types of cable are reliable when properly installed. Sheaths that are scraped and damaged in handling and pulling, and cables damaged by failure to maintain adequate radii are subject to premature failure. Lead-covered cable is particularly sensitive to mechanical damage and requires specially trained personnel to do the splicing. Thus, an increasing trend toward the use of nonmetallic sheathed cable having synthetic rubber or plastic insulation has been noted.

3.2.8 Using stress cones at cable terminations of shielded power cables

Use stress cones at cable terminations of shielded power cables. Stress cones reduce the voltage gradient at the termination of the cable shield and are desirable at voltages above 2 kV. Sufficient space should be

made available in electric equipment to facilitate the construction of stress cones. Rain shields, silicone-tape terminals, porcelain terminators, or other suitable methods are required for stress cones used on outdoor installations.

3.2.9 Fire-retardant cable

Use fire-retardant cable to minimize fire hazards. A careful choice of cable insulation and cable jacketing is recommended to minimize propagation of fires and generation of toxic gases. Fireproofing of power cables in manholes is recommended to minimize the number of circuits affected by a severe fault in the vicinity of manholes, cable trays, and wireways accommodating more than one circuit. Fireproof cables are also recommended from a personnel safety standpoint. When manholes are used, care must be taken to locate cabling where water and cement dust will not get into them.

3.2.10 Proper conduit size

Choose conduit size adequate for the cable to be used. Proper conduit size is of importance in facilitating cable installation with the minimum of cable damage. Conduit size is even more critical when pulling single-conductor cables, since three cables may jam if the triangular configuration is not maintained. Conduit sizes shall meet NEC requirements. To minimize cable damage when pulling wire, adhere to the recommended number of conduit turns between pull points (see NEC).

3.2.11 Choosing and installing cables for low-level signals

Use special care in the choice and installation of cables for low-level signals. Use separate ducts or physical separation of power and control cables. The possibility of elevated voltages on control circuits during fault conditions is always present when control cables are in intimate contact with power cables. Also, magnetic fields incident to power cables can cause unwanted noise pickup in sensitive control circuits.

Cables carrying signals that must be read accurately and that should have a minimum of noise should be given the following additional considerations:

- a) Electrostatic and magnetic shielding should be provided for each pair (or possibly groups of pairs) of cables. Cable shielding should be insulated and grounded at only one point to minimize noise pickup due to shield currents.
- b) Pairs of cables carrying low-level signals should be tightly twisted together to minimize noise pickup.
- c) Cable splices should be kept to a minimum.
- d) Physically separate power and control cables.
- e) Thermocouple leads should be compensating as determined by the thermocouples used.
- f) Isolating high-impedance transformers and/or filters are recommended for dc and inverter drives to reduce electrical noise and harmonics.

3.3 Secondary unit substations

The use of secondary unit substations to supply power under 600 V has become common in industry, generally resulting in more reliable and cost-effective installations.

3.3.1 Deriving power at utilization voltages of 600 V and less

Derive power at utilization voltages of 600 V and less by using individual secondary unit substations for each department rather than large centrally located units. Better voltage regulation, lower cable and equipment cost, lower cable power loss, and more flexibility are realized by the use of the smaller units located at load concentrations.

3.3.2 Utilization voltage of 480 V

Use 480 V as the utilization voltage. The use of 240 V results in a higher cost system both initially and in the form of cable costs and losses. The use of 600 V systems, although standard in Canada, is discouraged in the U.S. by the limited availability of equipment from stock in the U.S.

3.3.3 Radial distribution system

Use the radial distribution system. The radial distribution system is satisfactory for cement-plant service where department storage capacity allows independent departmental operation for short times. When an additional degree of continuity is desirable, such as in the kiln or slurry preparation department, a primary or secondary selective distribution system or both should be used.

3.3.4 Choosing secondary unit substation capacity

In general, choose secondary unit substation capacity, approximately 85% of the maximum operating horse-power connected to the secondary unit substations. The 85% figure varies in different operations and plant departments depending on the reserve capacity and overmotoring used. The 85% figure usually allows for addition of some future loads.

3.3.5 Limiting secondary short-circuit capacity within economical circuit-breaker ratings

Use secondary unit substations rated 1500 kVA or less (self-cooled rating) to limit secondary short-circuit capacity within economical circuit-breaker ratings. Where additional capacity is required in a department, a double-ended unit or additional secondary unit substations are usually used. In any event, secondary ties are normally operated open and only closed when a low-voltage substation transformer is out of service.

Secondary unit substations at 480 V up to 1500 kVA rating, 5.75% impedance, can usually be used to feed control centers braced for 42 000 rms symmetrical.

If the system-available short-circuit current exceeds the bracing and interrupting rating of the standard available motor control center supplied by a 480 V secondary unit substation rated greater than 1500 kVA, additional means of protection will be required.

Coordinated combinations of current-limiting fuses and molded-case circuit breakers can be used in the main incoming line circuit to limit fault duty on the small circuit breakers. Reactors, cable impedance, or additional impedance built into the secondary unit substation transformers can be used to limit fault currents.

Additional kilovoltampere secondary unit substation capacity, which does not add additional transformer short-circuit capacity, is available by fan cooling. However, the additional short-circuit capacity added by the additional load must be considered.

3.3.6 Primary fuses on the secondary unit substation primary

Use primary fuses on the secondary unit substation primary. The transformer secondary breaker should be set at not more than 250% rated current in supervised locations (see NEC). On circuits feeding large motors as well as secondary unit substations at the distribution voltage level, the large motor inrush may require feeder circuit breaker relay settings above that which is required for secondary substation protection. Where a small secondary unit substation is placed on the same circuit as a much larger load, the relay setting dictated by the larger load may be too high to protect the smaller substation. Fuses are required on the secondary unit substation not adequately protected by the feeder circuit breaker relays. A separate set of relays may be required instead in the feeder circuit breaker for the smaller loads.

Means should be provided to enable isolation of the secondary unit substation primary. A visible-blade disconnect switch, key interlocked with the main secondary circuit breaker, gives a visible indication of circuit isolation.

3.3.7 Fully rated low-voltage switchgear for feeder-circuit protection

Use fully rated low-voltage switchgear for feeder-circuit protection on secondary unit substations. Where desired, an additional degree of service continuity is available from the use of selective circuit breaker tripping, as only the faulted secondary unit substation feeder is isolated.

Some plants use control centers that are closed coupled to the transformer for economic and spatial reasons. The control center main air circuit breaker serves as the low-voltage feeder circuit breaker.

3.3.8 Main low-voltage breaker

Use a main low-voltage breaker on the secondary unit substation. A main low-voltage circuit breaker is recommended when:

- a) The transformer primary protection is by fuses, or the setting of primary protective equipment is above 250% rated transformer current. The main secondary circuit breaker permits much closer overload protection and facilitates interlocking with primary disconnecting means.
- b) The secondary system is connected to other sources of supply, such as through a tie breaker in double-ended unit or secondary selective systems. The main circuit breaker provides a means of isolating a transformer and its associated primary system from the secondary bus.
- c) The transformer is located at a considerable distance from the utilization equipment.
- d) There are more than six secondary feeder circuit breakers.
- e) The transformer secondary circuit breaker should have a continuous-current rating greater than the maximum forced cooled rating of the transformer.

3.3.9 Choosing and setting secondary circuit breaker trip units

Choose and set secondary circuit breaker trip units to quickly initiate the isolation of secondary faults. Suggested feeder trip units [continuous rating (A)] are outlined as follows.

3.3.9.1 Secondary feeder circuit breakers

Choose a current trip unit equal to the ampacity of the feeder cable as per Article 240-3 per the NEC.

Set the pickup value of the trip units only slightly above the normal load current expected. Set the long-delay setting to that value required to override the accelerating inrush of the largest motor. Set the

instantaneous setting only slightly above the maximum normal asymmetrical value of load current expected. This condition may occur when the load current consists of the normal load of the feeder plus the inrush current of the motor or motors being started. In no case should the feeder circuit breaker instantaneous trip setting be above 80% of the fault current expected at the load supplied by the feeder circuit breaker.

Sensitive ground fault tripping is recommended on each feeder to quickly isolate destructive arcing ground faults. All downstream ground faults will be cleared by the feeders if ground fault protection is not provided for the downstream protective devices. Feeders should have long, instantaneous, and ground trips if they are supplying a final load and long, short, and ground trips if they are not supplying a final load in order to achieve selectivity. Set ground relays at their minimum settings.

When selective tripping is desired on feeder circuit breakers, use a trip unit having a short delay instead of the trip unit with the instantaneous setting. However, the use of the short-time rating of the circuit breaker must be observed. The minimum time band short delay is used for selective tripping with the instantaneous molded-case circuit breaker used in the control center [see IEEE Std 242-1986 (*IEEE Buff Book*)].

Listed in the following table are 480 V alternating current interrupting and short-time ratings of commonly used circuit breakers.

Continuous rating (A)	Interrupting rating (RMS symm)	Short-time rating (RMS symm)
800	30 000	30 000
1600	50 000	50 000
3200	65 000	65 000

3.3.9.2 Secondary main circuit breakers

Choose the current trip unit and set the current pickup value at approximately 125% of the transformer full-load current.

The secondary main circuit breaker should have only long, short, and ground trips. Instantaneous trips would make it impossible to have selectivity with the downstream feeder breakers.

If used, set the instantaneous trip setting above the asymmetrical inrush of the largest feeder circuit breaker, and above the maximum normal peak current expected. This circuit breaker is not expected to coordinate with the feeder circuit breaker on faults above the instantaneous setting for the fully rated system.

As with feeder circuit breakers, sensitive ground fault tripping is recommended on the main circuit breaker, and may be required by the NEC.

3.3.10 Secondary unit substations in clean pressurized rooms

Locate secondary unit substations in clean pressurized rooms. The ventilated dry type and the less flammable liquid type secondary unit substation transformers are suitable for use in rooms that are ventilated and cleanly maintained. The less flammable liquid type transformers used indoors need to meet various requirements (see NEC). When located in the plant area or subjected to moisture and dust, the sealed dry-type or cast-coil or 10 c oil outdoor transformers apply. Secondary unit substation transformers should have terminal chambers to eliminate the settlement of dust and moisture on exposed bushings, enhancing safety to both personnel and equipment.

3.3.11 Use of delta primary and wye-connected secondary

Use delta primary, wye secondary connected secondary unit substation transformers. A secondary neutral bushing should be available for grounding each secondary unit substation transformer. The wye-connected secondary provides a neutral to ground the system. The delta winding stabilizes the neutral and suppresses harmonic voltages. When operated ungrounded, the secondary system should be equipped with ground detectors, and a ground should be cleared as soon as feasible. This can also be accomplished with a wye/delta bank.

Where a neutral is not available, zig-zag or wye-broken delta transformers can be used to establish a grounded neutral.

The solidly grounded secondary system is usually recommended [see IEEE Std 242-1986 (*IEEE Buff Book*)].

3.3.12 Limiting the voltage range to 10% of motor rating

Design the secondary system to limit the voltage range to 10% of motor rating. Adjust secondary unit substation transformer taps to have the rated transformer voltage available at the secondary unit secondary terminals under no-load conditions. With rated transformer voltage available at the secondary unit substation, a combined total of approximately 5% voltage drop is allowed to the motor for the motor to operate at rated voltage. Economic factors (see Figure 6 in Clause 7) indicate that motors 250 hp (200 kW mechanical output) and above should be energized at the 4160 V level, and motors 200 hp (150 kW mechanical output) and above should be energized at the 2400 V level, depending on the distribution voltage available.

Where automatic equipment requires closer regulation than 10%, the system design should consider these special requirements.

3.3.13 Indicating secondary voltage and current

Use metering to indicate secondary voltage and current. A visible indication of secondary unit substation loading is desirable to enable spot checks of equipment operation. An ammeter on each feeder circuit breaker is desirable also to indicate loading of individual control centers. One voltmeter and selector switch for the substation should be included.

3.4 Safety ground check monitoring

Safety ground check monitoring devices as approved by the Mine Safety and Health Administration (MSHA) are recommended on all portable-type equipment fed from trailing cables such as stacker and reclaimers. For cranes and hoists, a ground wire pickup is recommended (see MSHA CFR 30 Part 56 and MSHA CFR 30 Part 57).

4. Power distribution for a plant expansion

Many local factors not considered in new plant construction influence the choice of electric equipment in a plant expansion program. Age and condition of existing equipment, existence of generation capacity, voltage of existing systems, spare capacity availability, and other factors influence the choice of distribution equipment. Thus, it is difficult to generalize on recommendations when conditions vary so widely.

In small expansions, the addition of transformer fans or the addition of duplicate electric equipment will often satisfactorily serve to supply power to the new machinery. Larger expansions may require main plant

distribution substation equipment, secondary unit substations, and may be accompanied by partial retirement of existing equipment, either immediately or gradually.

When modernizing an electrical installation, government regulations may require replacement or modification of equipment that does not comply with government requirements. Whether the expansion is small or large, make sure the one-line diagrams are up to date, and documentation is available on the distribution system short-circuit calculations and relay coordination study. All types of studies are available to help decide which route to take. These can be voltage drop study, load flow study, energy management study, short-circuit study, protective device study, system-harmonic study, and ground system study. The type of study required depends on particular existing problems or deficiencies. At minimum, for all expansions, a short-circuit study and relay coordination study are a must.

Several comments are offered below for consideration as they apply to the expansion of an existing cement plant.

4.1 Changing 2400 V system to 4160 V if total expanded plant capacity exceeds 10000 kVA (self-cooled)

Consider changing the existing 2400 V system to 4160 V if the total expanded plant capacity will exceed 10 000 kVA (self-cooled). The 2400 V system becomes uneconomical above 10 000 kVA. The limited capacity of switchgear and motor control at 2400 V limits the substation capacity on a bus (see Figure 1 and Figure 2 in Clause 7).

4.2 Deriving utility power for existing 2400 V equipment from the high-voltage incoming line utility service or from the proposed new 4160 V system

Utility power for the existing 2400 V equipment can be derived either from the high-voltage incoming line utility service or from the proposed new 4160 V system with a 4160 V to 2400 V transformation. (Auto-transformers should not be used.) Care should be taken to ensure that the short-circuit capacity of the existing 2400 V switchgear and starters is not exceeded. The double transformation outlined above reduces short-circuit capacity at the expense of 4160 V substation capacity.

4.3 Grounding the existing 2400 V system through neutral-grounding resistors

Consider grounding the existing 2400 V system through a neutral-grounding resistor or resistors. The 2400 V transformer could be delta primary, wye secondary, to have a secondary neutral available. Where a system neutral is not available, derive a neutral by the use of a grounding transformer. Ground relays would be required and should be added on existing 2400 V feeders, as most older 2400 V systems were initially installed ungrounded. A wye/delta bank can also be used.

Grounding the 2400 V system through a resistor reduces fault damage as well as voltage stress on existing equipment during fault conditions [see IEEE Std 142-1991 (*IEEE Green Book*)].

4.4 Abandoning existing generation and purchase total power from the utility

Consider abandoning existing generation and purchase total power from the utility. The trend has been in the past 20 years toward the retiring of existing generation capacity and purchasing power from the utility, especially if the existing installation is more than 20 years old.

The economics involved in continuing or abandoning generation depends heavily upon local conditions. Coordination with the utility is required when generation is to be paralleled with the utility system. Other co-generation opportunities should be investigated.

4.5 Using interlocked armored cable carried on trays

Consider the use of interlocked armored cable carried on trays. The addition of new circuits in an existing installation is often required after the duct system is filled up and new ducts or conduits are found difficult to install. The installation of armored cable on racks or trays is particularly convenient as ducts are not required. Interlocked armored cable should include ground wires to ensure an adequate return-current path during fault conditions. Where interlocked armor is subject to corrosion, a protective coating on the armor is recommended. Galvanized steel armor is preferred over aluminum to minimize alkali attacks and will also reduce magnetic noise in adjacent conductors.

Care must be taken to ensure that the NEC and plant insurance fire protection requirements are met for tray installations. Trays must be located in protected areas.

Long-term viability vs. initial installation cost should be evaluated before proceeding on tray installations. Conduit systems should be utilized to compare long-term integrity of conduit vs. cable trays.

5. Quarry distribution utilizing high-resistance grounded systems for portable electrical equipment

Special problems exist in the quarry that are not normally problems in the plant proper. The use of portable equipment and the widely varying ground impedance that exists in the quarry necessitate grounding precautions to minimize shock hazards. Also, the use of long lines and cables feeding concentrated loads give rise to voltage-regulation problems.

This clause outlines preliminary recommendations for the quarry distribution system. MSHA's notebook, *Electrical Hazards Awareness Program*, shall be considered for quarry distribution systems.

5.1 Quarry distribution transformer

Along with size and voltage level, the system grounding method shall be carefully considered when selecting a quarry distribution transformer.

5.1.1 Sizing the quarry distribution transformer

Size the quarry distribution transformer at approximately 2 kVA per connected horsepower. The load reflected by shovels and draglines during normal operation is cyclic, and the rms load will normally be slightly less than the machine continuous rating. The 2 kVA/hp rating may result in a slightly oversized transformer where several shovels are used. However, the transformer size is justified by better voltage regulation and margin for additional loads. A larger distribution transformer capacity is required to keep voltage regulation within tolerable limits during full-voltage starting and peak loading of motors that approach the size of the substation.

5.1.2 Delta primary, wye secondary isolation transformer to supply quarry equipment

Use a delta primary, wye secondary isolation transformer to supply the quarry equipment when the power source to the quarry is not already safety resistance grounded. Almost all existing cement-plant main substations are either solidly grounded, low-resistance grounded, or ungrounded at the primary distribution-voltage level. Thus, a quarry distribution transformer is almost always required to isolate the main-plant system from the quarry system and enable the high-resistance safety grounding of the quarry portable equipment. A fully insulated transformer secondary neutral bushing should be available (see Figure 9 in Clause 7).

5.1.3 Automatic circuit-interrupting device

Use an automatic circuit-interrupting device on the quarry substation primary. The primary protective device is a circuit breaker or a high-capacity fused starter. Use of these automatic devices allows the use of protective relays, which are sensitive to the low secondary ground-fault currents, and operate to isolate ground faults not seen by primary fuses. Use of only primary fuses and a secondary circuit breaker results in an area of unprotected exposure on ground faults between the transformer and the secondary breaker. A means of remote tripping a primary breaker on these ground faults should be provided. When a ground fault occurs between the transformer secondary and the line side of the switchhouse circuit breakers, it can only be cleared by detecting the secondary ground and remotely tripping the transformer primary circuit breaker (see Figure 9 in Clause 7).

5.1.4 Safety neutral resistance-grounded system at the primary distribution voltage

Use a safety neutral resistance-grounded system at the primary distribution voltage in the quarry. The safety grounded system recommended for quarry operations requires the limiting of single line-to-ground fault current to a low value and carrying a ground wire from the earth ground point of the resistor to the frames of the portable equipment. Resistors commonly used limit the maximum ground-fault current flow to either 25 A or 50 A. The final result desired from the system is to limit equipment frame-to-ground voltage to less than 100 V during single line-to-ground faults. In addition to limiting frame-to-ground voltages to safe levels, the safety grounded system limits the damage to equipment during ground faults. The unfused potential transformer with the primary connected across the grounding resistor and its secondary connected to an inverse time potential relay will initiate the isolation of the supply on ground faults, even with an open circuit in the ground resistor [see IEEE Std 142-1991 (*IEEE Green Book*)].

5.1.5 Extended time rated neutral-grounding resistor to limit single line-to-ground fault current

Use an extended time rated neutral-grounding resistor to limit single-line-to-ground fault current. Use of an extended time rated resistor helps ensure that the grounding system will not be rendered ineffective if for some reason a ground fault is not immediately isolated. The resistor and ground wire combination will continue to limit fault current and frame-to-ground voltage as long as the ground fault is on the system. Grounding transformers, where used to derive a neutral, should be continuously rated and be of low (2% to 5%) impedance [see IEEE Std 142-1991 (*IEEE Green Book*)].

5.1.6 Separating the quarry distribution substation ground grid from safety ground grid

Separate the quarry distribution substation ground grid from safety ground grid. A minimum distance of 15 m (50 ft) is recommended. This separation helps minimize the voltage of the safety ground wire due to the rise in substation ground grid potential during primary ground faults and lightning surges. Resistance to earth of the main grid should be no more than 2 Ω . The safety ground grid should be no more than 5 Ω to earth.

In some areas where the earthen ground conditions are very poor, an elaborate grid system may be required in order to meet these resistance-to-earth ohmic values.

The burial of metal pipes, water lines, etc., should not reduce the 15 m (50 ft) minimum separation between the substation ground grid and the safety ground grid.

All of the substation equipment, frames, fence, structures, and lightning arresters tie to the substation ground grid. The safety ground grid ties only to the safety ground wire at the substation. The safety ground wire should be insulated in the vicinity of items grounded to the main ground grid, so a person does not bridge two grounds [see IEEE Std 142-1991 (*IEEE Green Book*)].

5.1.7 Limiting the impedance of the ground

Limit impedance of the ground wire connecting the safety ground grid to the portable equipment frame so that the frame-to-ground voltage will be held to a safe value during single-line-to-ground faults. A frame-to-ground voltage of 100 V has been used as a maximum safe value in quarry system design. A man standing on earth and touching the frame of the portable equipment during a ground fault is subject to the approximate voltage drop in the ground wire.

Thus, the product of maximum ground-fault current and ground-wire impedance must be kept below 100 V (see NEC).

With the ground-wire impedance of 2 Ω and a 50 A neutral resistor, the frame-to-ground voltage would be approximately two times 50, or 100 V. If ground-fault current were limited to 25 A, the frame-to-ground voltage would be about 50 V during the ground fault, with a 2 Ω ground wire.

Loss of the safety ground wire renders the safety grounded system ineffective against shock hazard. Therefore, continuous monitoring of ground-wire continuity is required and isolates the circuit either in the cable pilot wire or ground wires. An extremely low frame-to-ground voltage of less than 24 V should be utilized at the power source to minimize personnel shock hazards.

The pilot wire can also be used for remote tripping of the primary breaker and electrically interlocking cable receptacles and switches [see IEEE Std 142-1991 (*IEEE Green Book*)].

5.2 Primary distribution

5.2.1 Realize not less than rated portable equipment voltage in normal operation

Design the quarry primary distribution system to realize not less than rated portable equipment voltage in normal operation. A 20% system voltage drop at the motor terminals during motor starting is acceptable. Shovel and dragline motors are usually rated approximately 10% below system transformer voltage, so that a 10% system drop is allowable for normal operation. For example, shovel and dragline motors are rated 3810 V for a 4160 V system and 2200 V for 2400 V system. Normally, industrial motors are rated 4000 V and 2300 V when used on 4160 V and 2400 V systems, respectively.

5.2.2 Using a pole line

Use a pole line to distribute power at the primary distribution voltage from the quarry distribution transformer to the quarry portable equipment. The use of a pole line to carry power to the area of the portable machine is desirable to keep cables off the ground and less subject to damage from quarry equipment. This pole line could be messenger cable, mine power cable, or open wire.

The use of open-wire line is preferred by some engineers since the open line provides a degree of flexibility at the lowest cost. Damages to the line that occur during normal operations can be repaired at a lower cost with a minimum of down time. However, the voltage regulation of the open line is usually greater than cable because of the relatively high reactance. Consider voltage drop carefully, especially during shovel and dragline motor-generator set starting when using the open line. A fourth conductor to carry the quarry distribution transformer safety ground to the vicinity of the portable machines is required (see NESC).

The messenger cable with suspension line has less reactance than open line and should be considered when voltage regulation is a problem. The suspension line can be used as the ground wire to carry the safety ground to the portable cables. However, care must be used to ensure that the overall ground wire impedance from the quarry substation to the portable equipment at the distribution voltage is less than 4 (with the 25 A safety ground source) or less than 2 Ω (with 50 A safety ground source).

Mine power cable with individual conductor shielding and ground wires in the cable interstices offers a greater degree of safety at greater cost. The voltage regulation is the lowest of the above lines, and ground wires are built into the cables for carrying the safety ground to the area of the portable equipment at the distribution voltage. Phase-to-phase faults are discouraged by the individually shielded conductors. Cables with a pilot wire are available to enable the continuous monitor of ground-wire continuity, a valuable safety feature.

Mine power cable is the most difficult to repair, requires the greatest care in splicing and terminating, and ground faults on the safety grounded system are difficult to locate. However, the safety features and good voltage regulation inherent in the all-cable system are felt to outweigh these disadvantages. The trend is toward the all-cable system.

5.2.3 Sizing the pole-line conductors

Size the pole-line conductors to be adequate for the thermal capacity and voltage regulation required in the quarry. Cables and open-line conductors based on thermal capacity alone may result in prohibitive voltage regulation. Consider the overall system voltage regulation as outlined in when choosing conductor sizes.

5.2.4 Lightning protection of overhead feeder lines and large rotating apparatus

Provide for lightning protection of overhead feeder lines and the large rotating apparatus in addition to the surge-protective equipment used at the quarry substation. Surge arresters should be installed at either end of the overhead lines and at each tap point feeding loads at primary distribution voltage greater than 15 m (50 ft) from the safety ground connections to earth. For equipment protection, surge arresters and surge capacitors should be located close to [less than 1 m (3 ft) from] the terminals of the equipment to be protected, and connected to low surge impedance grounds. Additional protection is recommended by placing surge arresters 500 m to 650 m (1500 ft to 2000 ft) ahead of terminations going to rotating equipment.

Surge arresters for the high-resistance safety grounded system used in the cement-plant quarry should be rated for line- to-line voltage. Surge arresters are required by MSHA regulations.

5.2.5 Portable switchhouses

Use portable switchhouses to protect the quarry portable equipment. Portable switchhouses include circuit breakers that enable automatic isolation of the faulted equipment on both phase and ground faults. A switch or other means of providing a visible means of circuit isolation is desirable ahead of the switchhouse circuit breaker.

The switch or other means of providing the visible means of circuit isolation could be at the tap point of the cable at the pole line, in the switchhouse enclosure, or both. In any event, for safety reasons, it is desirable to interlock the disconnect means with the switchhouse circuit breaker to prevent the disconnect from being opened under load. Where the switchhouse is located remote from the pole line termination, a disconnect in the switchhouse, mechanically interlocked with the circuit breaker, is desirable, providing a local visible means of circuit isolation (see Figure 9 in Clause 7, 5.1.7, 5.2.8, and MSHA CFR 30 Part 56 and Part 57).

5.2.6 Standard for manufacturing trailing cables for shovels, draglines, and drills

Trailing cables for shovels, draglines, and drills used in the quarry should be manufactured to Insulated Cable Engineers Association (ICEA) standards. (The cable classification should be Type SHD.) The Type SHD cable is recommended for portable equipment, since it is designed to provide the flexibility required

for this type of service. The braided shield over each conductor plus the increased conductor stranding allows the cable to be handled with much less danger of damaging the cable.

In addition, Type SHD cable provides the greatest protection to both personnel and equipment, since a shield surrounds each power conductor. Type SHD cables are available with a pilot wire to enable the continuous monitoring of ground wire continuity, a valuable safety feature.

5.2.7 Care of trailing cables

Trailing cables should be handled with care and maintained properly. The life of a trailing cable depends heavily upon the amount of mechanical handling and abuse to which the cable is subjected. Cable life is seriously reduced by dragging, by kinking from too short a bending radius, and by crushing from vehicle traffic and rock slides. Store surplus cable on skids.

Stress cones shall be grounded on the ends of cable since the lack of stress cones is a major contributing factor to cable faults.

All splices should be done by an experienced splicer and according to the recommendations of the cable manufacturer.

5.2.8 Cable plugs and receptacles to facilitate equipment moves

Use cable plugs and receptacles to facilitate equipment moves in the quarry. Multiconductor cable receptacles are available with ground, phase, and pilot-conductor prongs. This enables quick connecting and disconnecting of de-energized circuits in the quarry. The pilot prong separates first upon disconnecting the plug and receptacle, enabling electric interlocking so that the backup circuit breaker trips to protect the worker who inadvertently attempts to disconnect an energized cable receptacle. Cable receptacles are also available with provisions for key interlocking to mechanically prevent them from being connected or disconnected while energized.

5.2.9 Special sensitive relaying

Special sensitive relaying is required in the quarry because of the low ground-fault currents involved. Suggested relaying is outlined as follows.

5.2.9.1 Quarry substation primary breaker

The options of the different relays of inverse time, moderately inverse time, very inverse time or extremely inverse time for both phase and ground should be compared to the new technology solid state microprocessor-based systems now available. The advantages of the new solid state units are many, including communications with a computer monitoring system, closer coordination, lower cost, and built-in metering.

- a) *Phase*. Very inverse, moderately inverse, or inverse time relays, or equivalent, with instantaneous trip attachments to isolate dangerous overloads and faults.

Instantaneous trips should be set above the maximum secondary asymmetrical fault current (referred to the primary) available at the transformer. Time settings are to coordinate with the switchhouse breakers and with backup breakers supplying the quarry substation from the main plant substation. Allow a minimum of 0.4 s (at maximum fault) longer time for the main breaker relays than the switchhouse phase relays.

- b) *Isolating transformer-primary ground protection.* Inverse, very inverse, or extremely inverse time relay, or equivalent, to be energized from the current transformer(s) located in the primary breaker. This relay will operate to trip the breaker on primary ground faults. Pickup should be less than 10% of the maximum available ground-fault current.
- c) *Isolating transformer-secondary ground backup protection.* Extremely inverse, very inverse, or moderately inverse time relay, or equivalent, to be energized from the current transformer located in the substation transformer-secondary neutral. This relay operates to trip the primary breaker on secondary ground faults and is to coordinate (by time) with the instantaneous ground relays located in the switchhouse. Additional protection is obtained by utilizing a potential transformer and relay as discussed in Clause 4.

When a high-capacity fused starter is used for primary protection, the contactor to be relayed should be capable of interrupting the current it may be expected to interrupt. Fuses will not see the ground-fault current as limited by the neutral-grounding resistor in the quarry transformer secondary neutral. The contactor operates on ground faults, and the fuses back up the contactor on severe phase faults [see IEEE Std 242-1986 (*IEEE Buff Book*)].

5.2.9.2 Quarry distribution transformer secondary breaker (when used instead of primary breaker)

The options of the different relays of inverse time, moderately inverse time, very inverse time, or extremely inverse time for both phase and ground should be compared to the new technology solid state microprocessor-based systems now available. The advantages of the new solid state units are many, including: communications with a computer monitoring system, closer coordination, less costly, and built-in metering.

- a) *Phase.* Very inverse, moderately inverse, or inverse time relays, or equivalent, to quickly isolate dangerous overloads and faults. The time setting is to coordinate with switchhouse breakers and backup breakers supplying the quarry from the plant distribution substation.
- b) *Ground.* Extremely inverse, very inverse, or moderately inverse, time relay, or equivalent. This relay is energized from a current transformer in the substation transformer neutral and is to coordinate (by time) with the switchhouse relays (see 3.1.15.4 for primary breaker recommendations and for potential transformer and relay scheme).

5.2.9.3 Switchhouse

- a) *Phase.* Long time or inverse time relays, or equivalent, with instantaneous trip attachments to override the shovel and dragline accelerating inrush, provides some measure of cable thermal protection. Phase faults are instantaneously relayed. These above relays are to coordinate with backup protection.
- b) *Ground.* Instantaneous. This relay should be energized from a balanced flux current transformer (window type) to realize sensitive instantaneous ground relaying without the nuisance tripping associated with residual-current relaying on circuits feeding large motors. Pickup value of this relay should be as low as feasible to pick up high-resistance faults. At least a pickup value of 25% of the maximum ground-fault current is desirable to protect 75% or more of motor and transformer windings on ground faults [see IEEE Std 242-1986 (*IEEE Buff Book*)].

5.3 Distribution 600 V and below

As with the quarry distribution transformer, distribution at under 600 V must consider the system grounding method for personnel safety as well as the required capacity.

5.3.1 Capacity of portable quarry low-voltage substation

The capacity of the portable quarry low-voltage substation should be approximately 1 kVA per connected horsepower. Capacity is also influenced by the maximum voltage drop tolerated. Voltage range for the secondary system should be within 10% of rated motor voltage.

5.3.2 Portable cables to feed portable loads

Use portable cables to feed portable loads at 600 V and below. The same advantages from using the portable cable with ground and pilot wires in the interstices at the primary distribution-voltage levels are also available at the 600 V and below level. It is also desirable to use shielded cable to the portable low-voltage equipment to discourage phase-to-phase faults, enhancing safety to both personnel and equipment.

5.3.3 Safety neutral resistance-grounded system for feeding the portable loads

Use the safety neutral resistance-grounded system for feeding the portable loads at the utilization-voltage levels of 600 V and below. Again, the limiting of ground-fault current to a low value (25 A or less) and using a metallic ground wire to the frame of the connected electric equipment is recommended to maintain safety to shock hazards. It is not required to separate the low-voltage safety ground grid from the safety ground at the primary distribution-voltage level, since the safety grounded system at the primary distribution-voltage level limits the elevation of the low-voltage substation secondary frames from earth potential.

A delta primary, wye secondary transformer (with fully insulated neutral) is preferred. Where a secondary neutral is not available, a small (approximately 5 kVA) zig-zag grounding transformer is used to derive a neutral. Continuously rated grounding transformers and resistors should be used.

Air circuit breakers usually provide secondary protection for feeder circuits. Phase protection is affected by inverse time and instantaneous trip units. Ground-fault relaying is affected by balanced flux current transformers energizing sensitive ground-fault tripping for each feeder circuit [see IEEE Std 142-1991 (*IEEE Green Book*)].

5.3.4 Use of a ground wire monitoring device

A ground wire monitoring device must be used on all portable equipment fed by trailing cables. The device will continuously check the continuity of the trailing cable's safety ground wire (see NEC).

6. Harmonics

With the trend toward more and larger adjustable frequency drives, the possibility of harmonic problems on cement plant power distribution systems must be considered. These problems may be manifested in electrical noise, damaging harmonic voltages associated with parallel resonance, and excessive fuse blowing on capacitors.

General considerations only are noted here. These are offered as a guide. Where rule-of-thumb limits are approached, it is recommended that appropriate filters and isolating transformers be included in the design to suppress harmonics.

The following are general considerations:

- a) *Make a study to determine the short-circuit ratio on the plant load bus, that is, primary distribution voltage.* A rule of thumb is that if the short-circuit ratio is more than 20, the possibility of harmonic problems is low.

$$\text{Short Circuit Ratio} = \frac{\text{load bus short circuit MVA}}{\text{total converter MW}}$$

- b) *Make a study to determine the probability of harmonic problems with shunt capacitor banks.* If the per unit frequency is close to the 5, 7, 11, or 13th harmonic, there is a probability of producing excessive harmonic voltages and currents, since the SCR equipment (6 pulse) typically generates $6N \pm 1$ harmonics (see IEEE Std 141-1986).

$$\text{Frequency (per unit)} = \left(\frac{\text{load bus short circuit MVA}}{\text{capacitor bank MVA}} \right)^{\frac{1}{2}}$$

- c) *Isolate harmonic generating equipment from the plant bus by isolating transformers.* Use of isolating transformers help prevent the electrical noise from affecting other equipment.
- d) *Make a plant harmonic voltage and current distortion study.* See IEEE Std 519-1992.

7. Figures

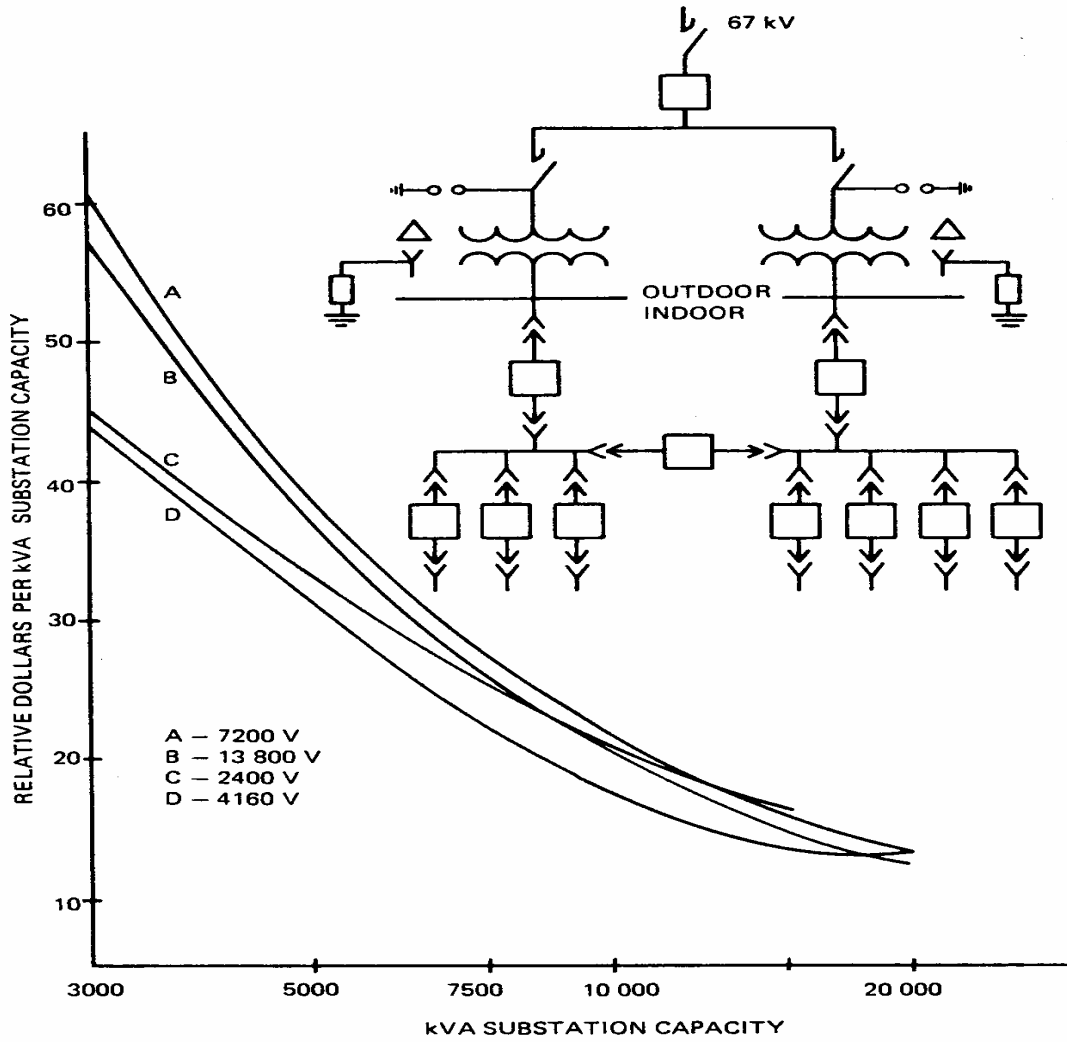

Figure 1—Economic comparison of double substations

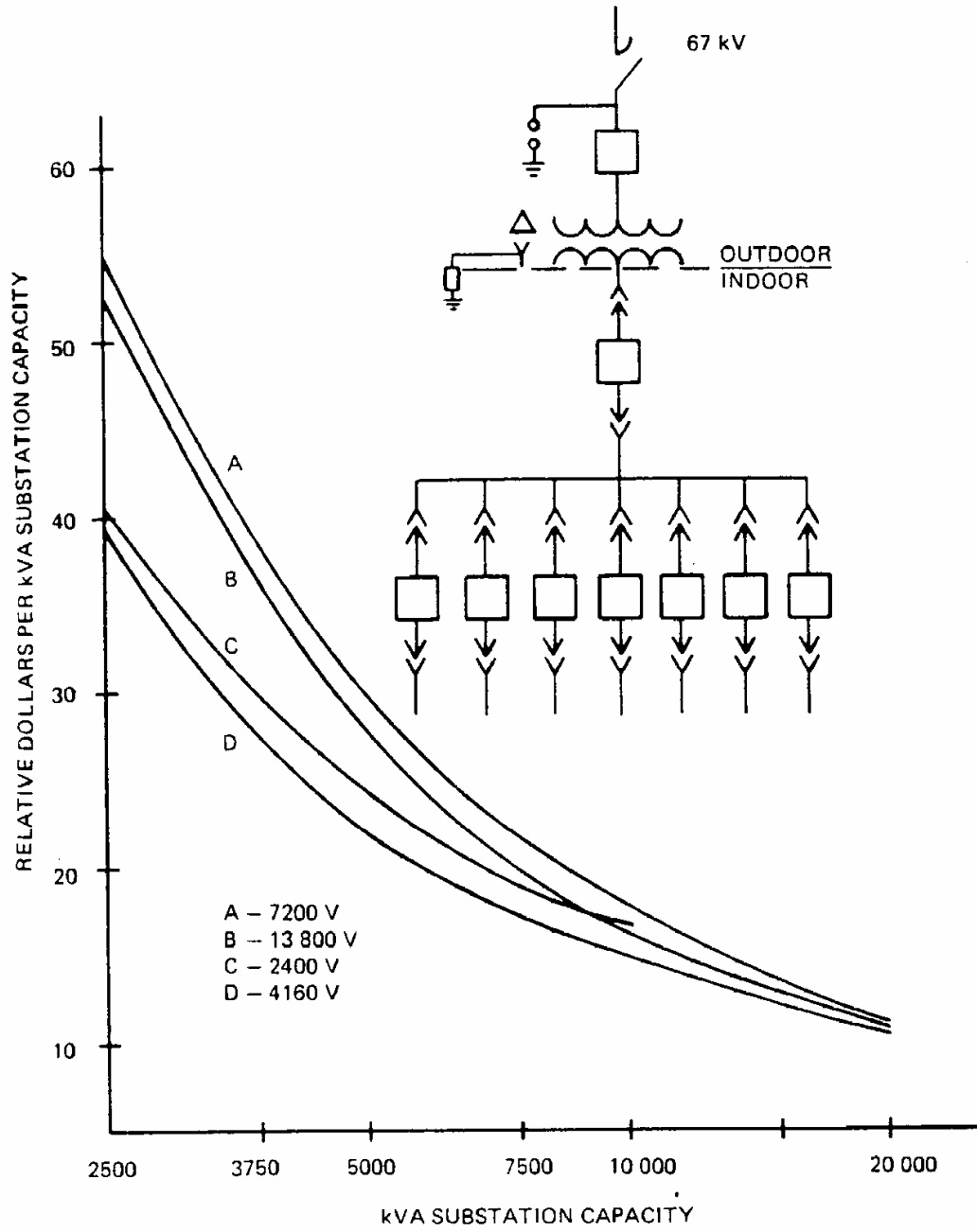

Figure 2—Economic comparison of single-ended substations

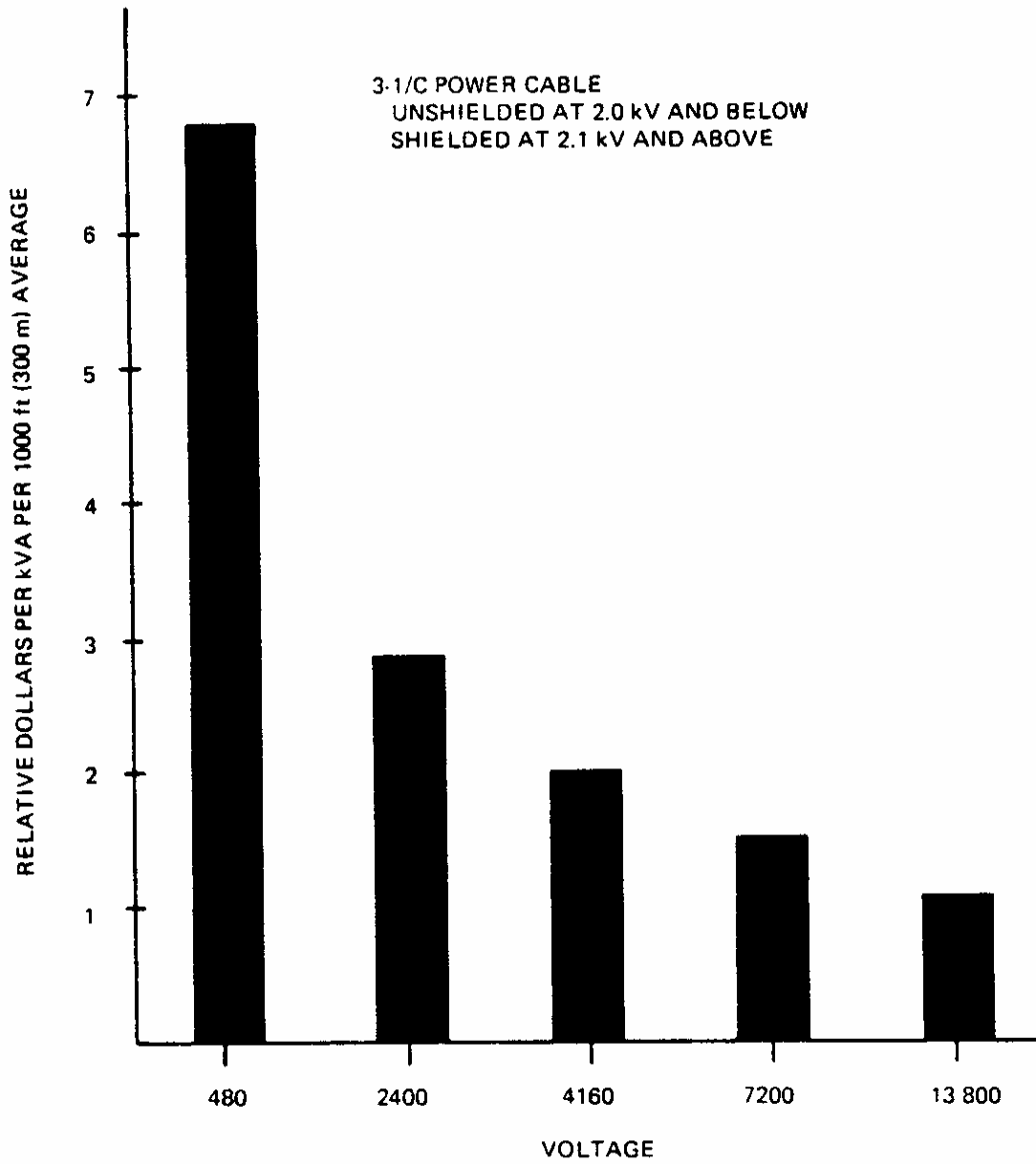

Figure 3—Economic comparison of cable

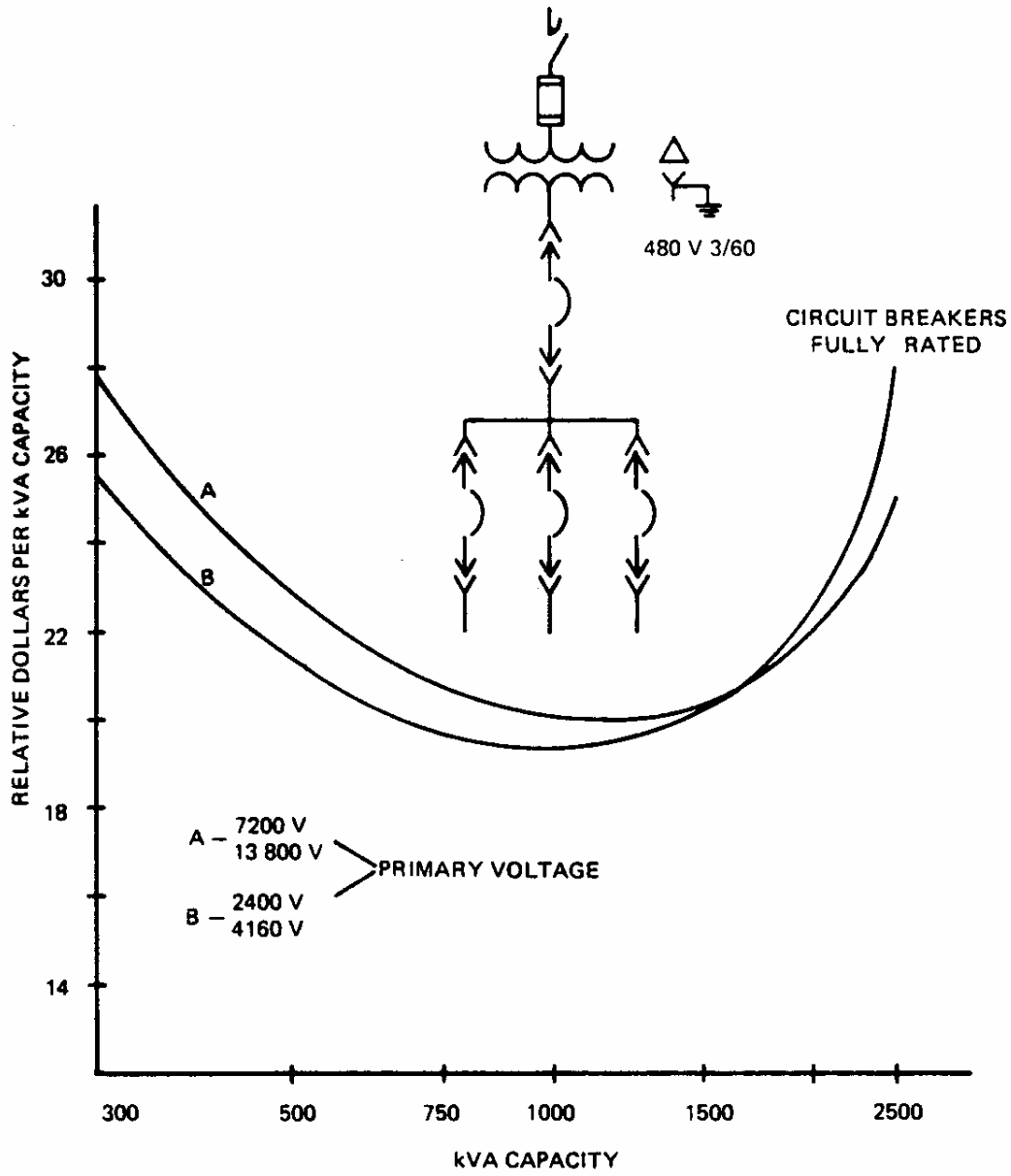

Figure 4—Economic comparison of indoor secondary unit substation

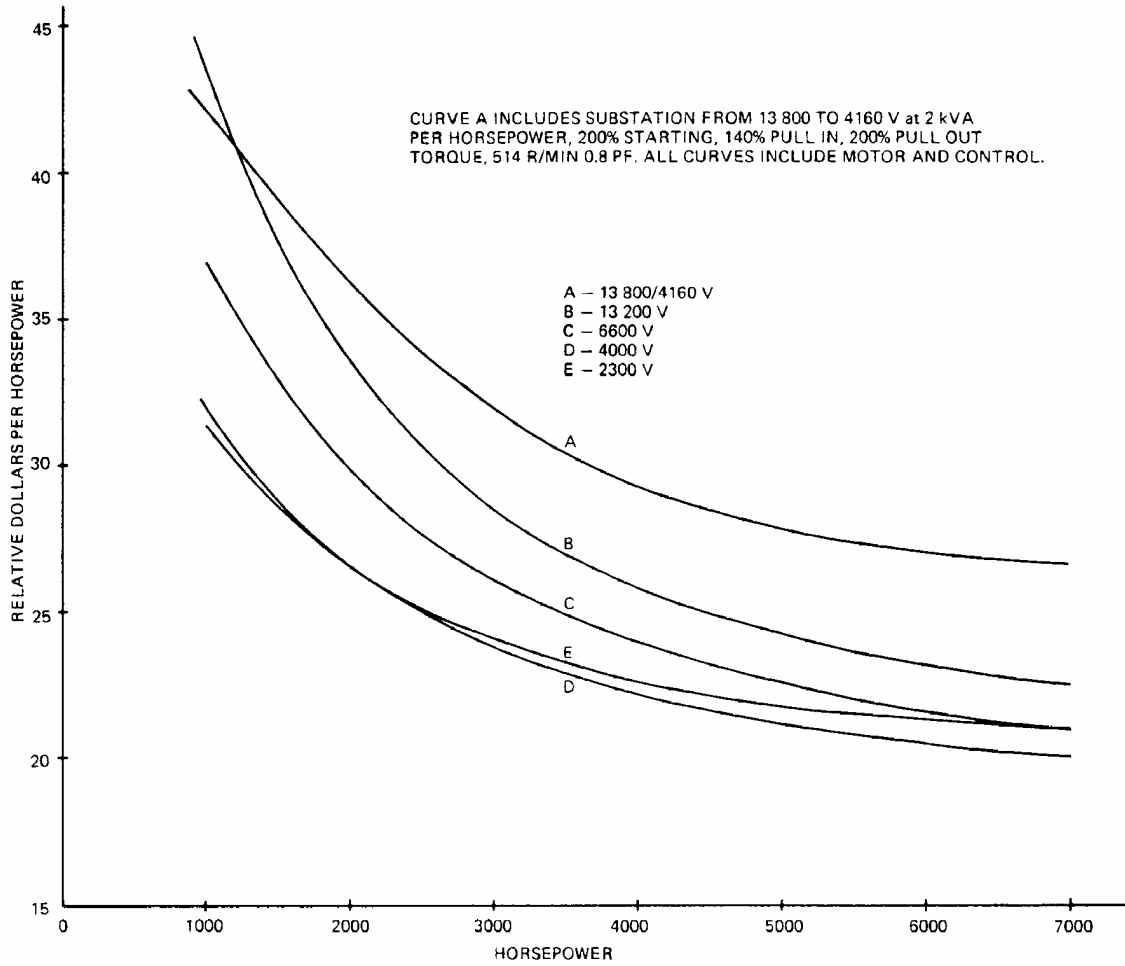

Figure 5—Economic comparison of ball mill drive

NOTE 1—Curve A: Substation from 13 800 V to 4160 V at 2 kV A/hp 200% starting, 140% pull in, 200% pull out torque, 514 r/min, power factor 0.8.

NOTE 2—All curves include motor and control.

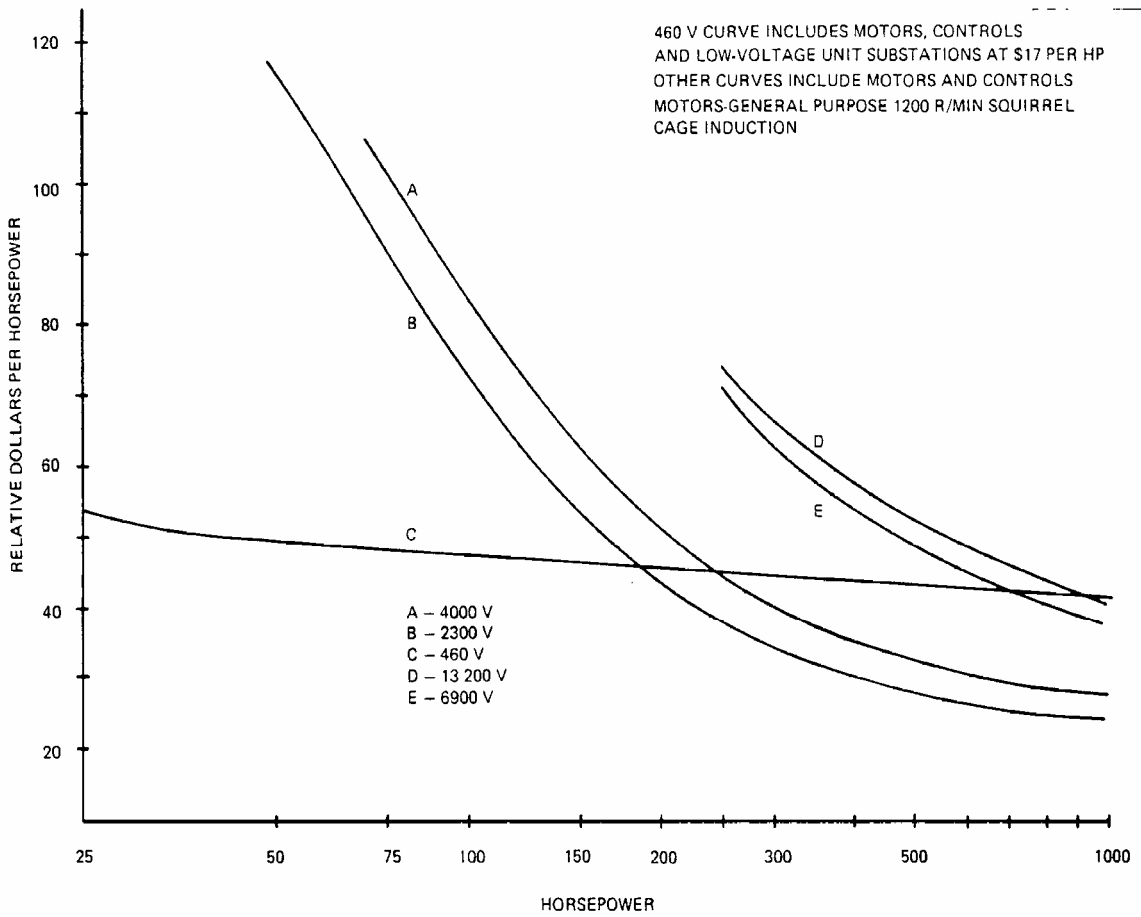

Figure 6—Economic comparison of motor voltages

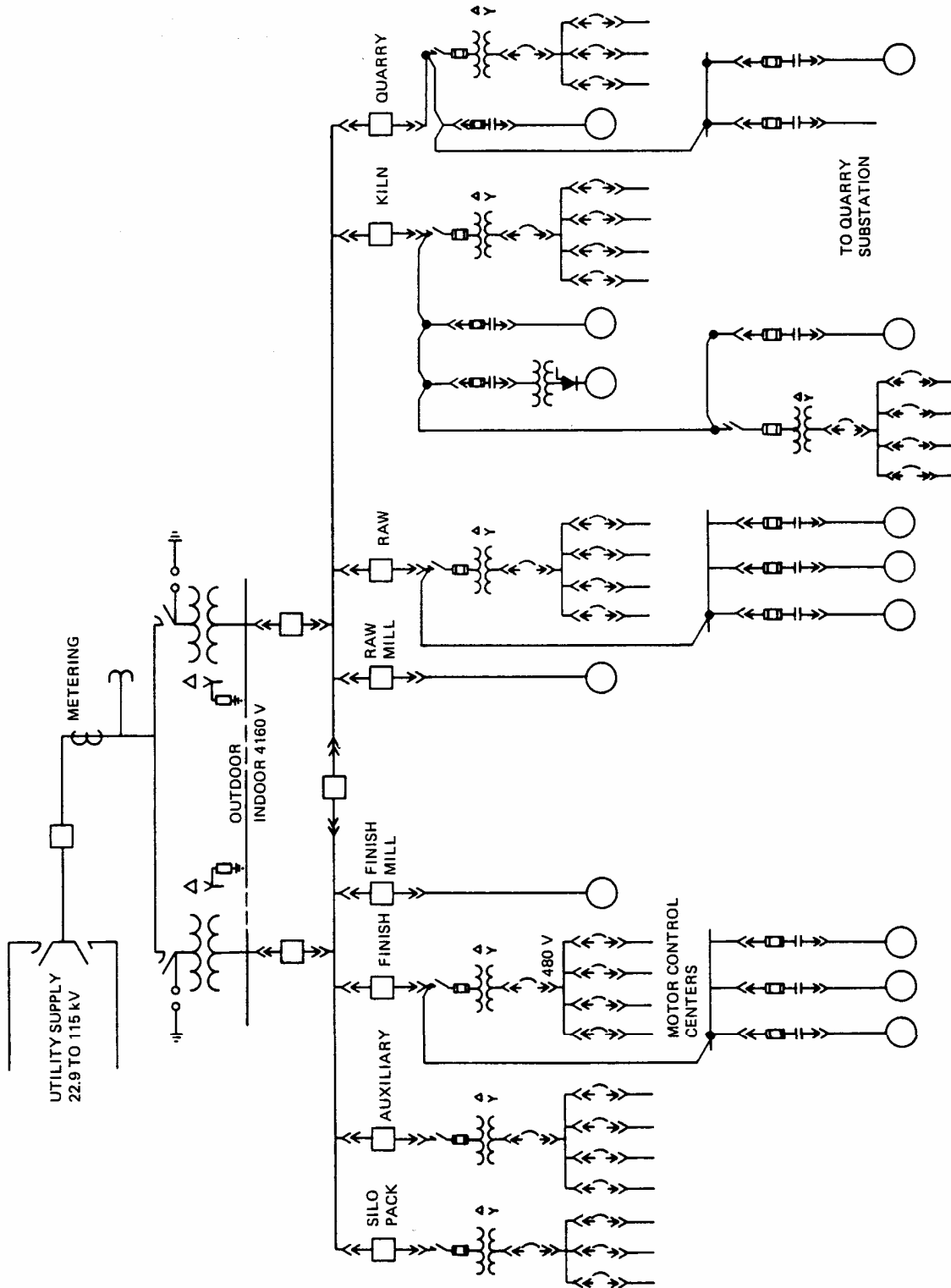

Figure 7—Typical cement plant distribution system

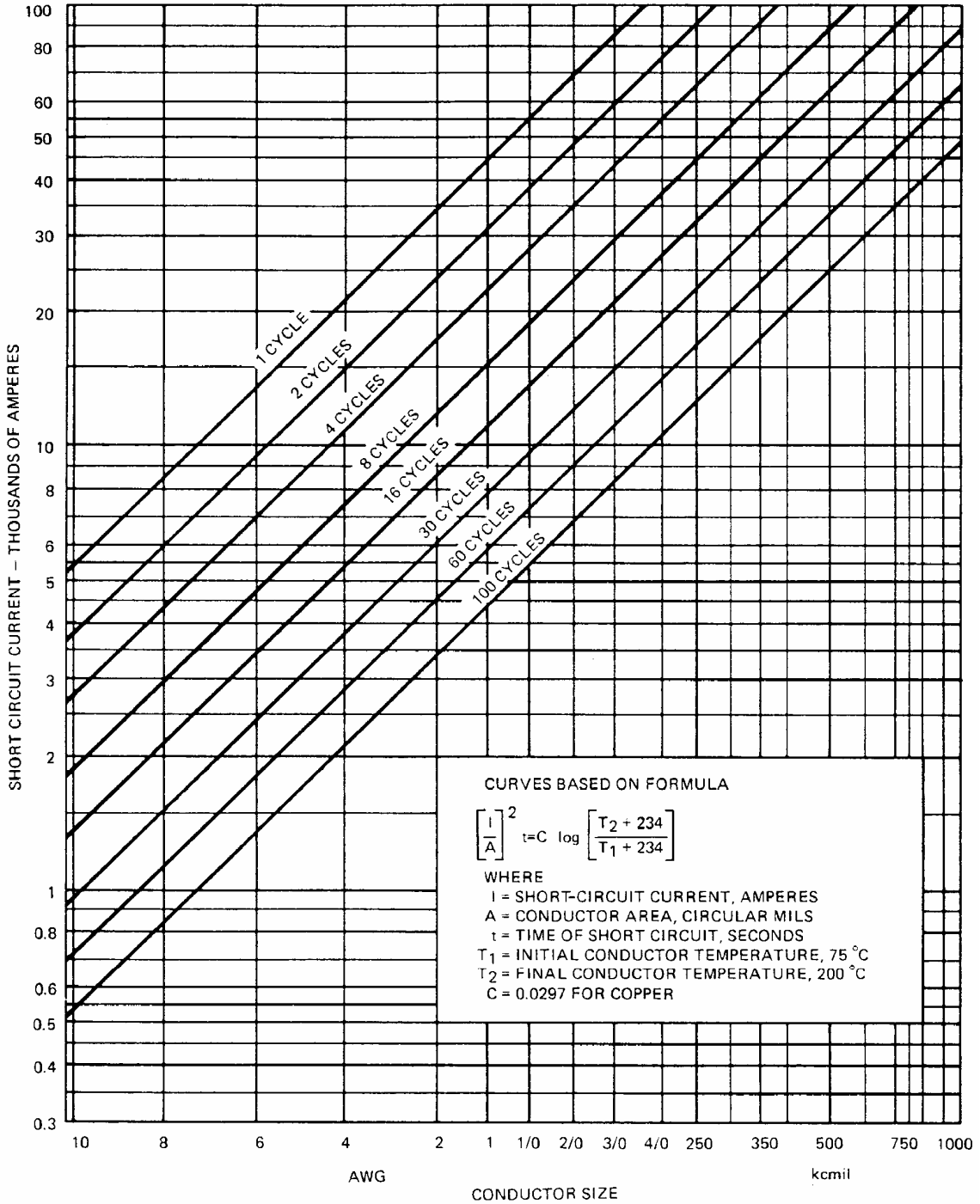

Figure 8—Maximum allowable short-circuit current copper conductor

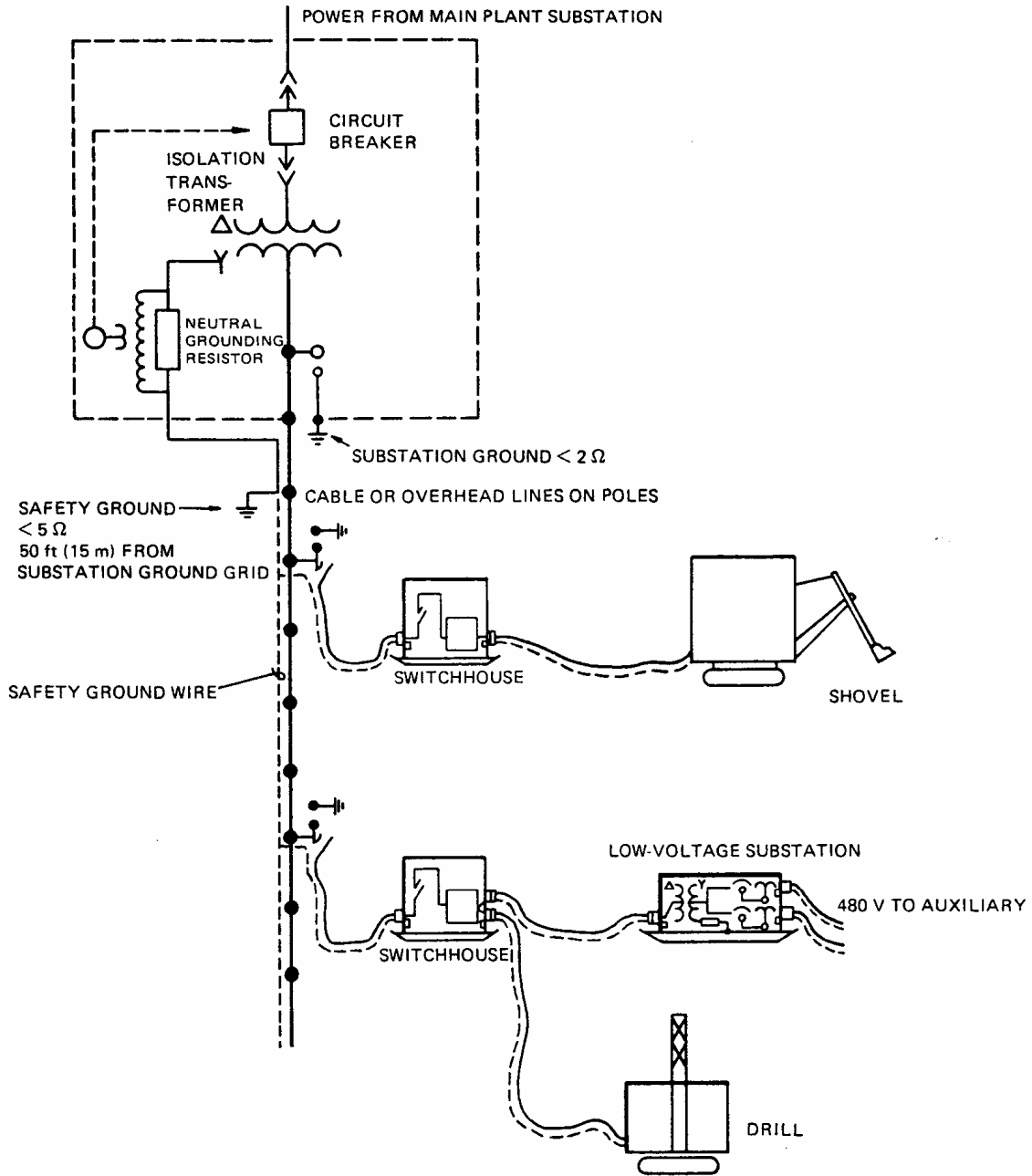

Figure 9—Quarry distribution